

ANSYS[®] Workbench

Tutorial

ANSYS Release 10

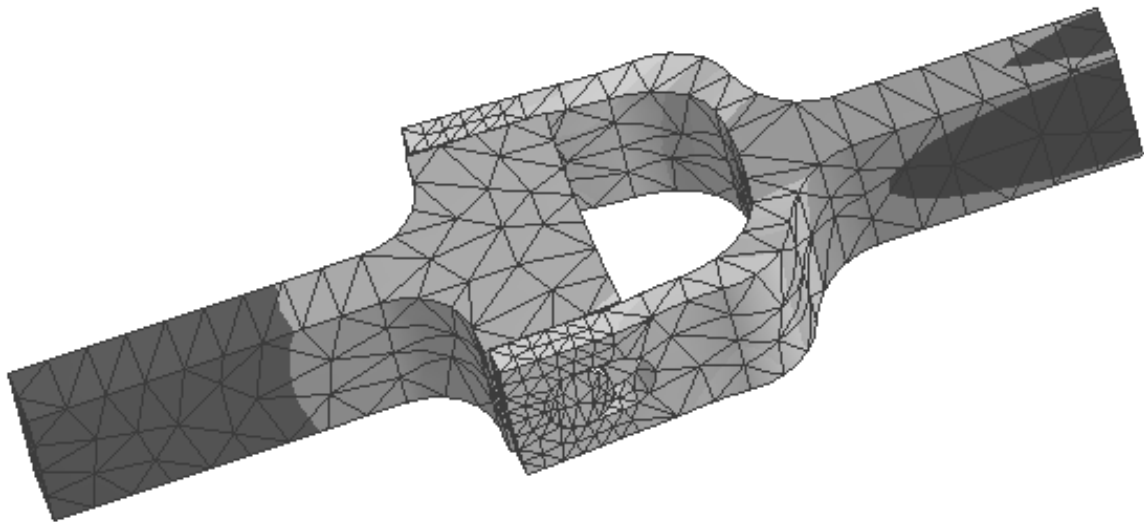

Kent L. Lawrence
Mechanical and Aerospace Engineering
University of Texas at Arlington

SDC
PUBLICATIONS

Schroff Development Corporation

www.schroff.com
www.schroff-europe.com

Chapter 1

Solid Modeling Fundamentals

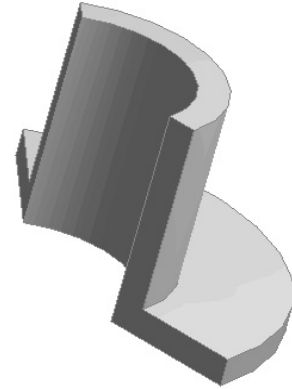

1-1 OVERVIEW

A simple L-shaped cross section is used to introduce basic solid modeling concepts with ANSYS DesignModeler. These tutorials explore modeling by:

- ◆ Extruding
- ◆ Revolving
- ◆ Sweeping

A number of additional parametric, feature-based modeling possibilities and formulations are demonstrated in this chapter.

1-2 INTRODUCTION

Solid modeling can be accomplished in a number of ways, and one favorite method involves starting with a two-dimensional shape and manipulating it to create a solid. That is the approach we will use for many of object models created in this book. Figure 1-1 shows an L-shaped cross section that has been variously **extruded**, **revolved**, or **swept along a curve** to produce the solid object models shown.

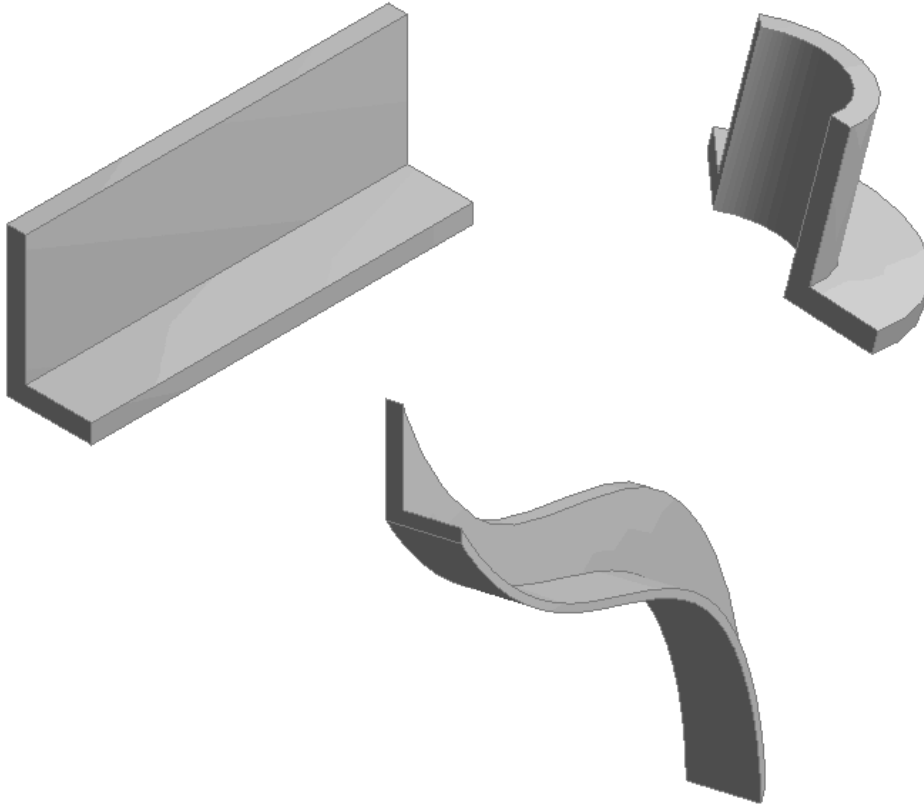

Figure 1-1 Extruding, revolving, sweeping an L-shaped section.

In the following we use the simple L-shaped section to illustrate these three fundamental solid modeling approaches.

1-3 TUTORIAL 1A – EXTRUSION

Follow the steps below to create a solid model of an extrusion with an L-shaped cross section.

1. Start ANSYS Workbench



Figure 1-2 Start ANSYS Workbench in Windows.

The startup menu allows you to retrieve old files, begin a new DesignModeler geometry, start a Simulation or initiate a New Project. Select **New geometry**.

2. Select New > Geometry

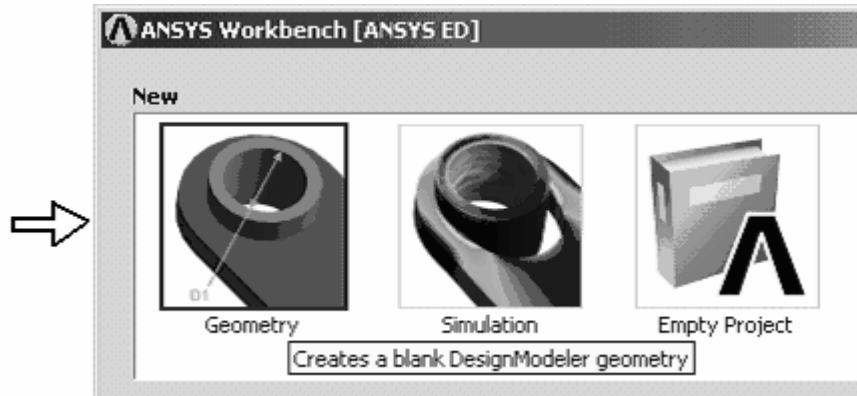

Figure 1-3 ANSYS Workbench startup menu.

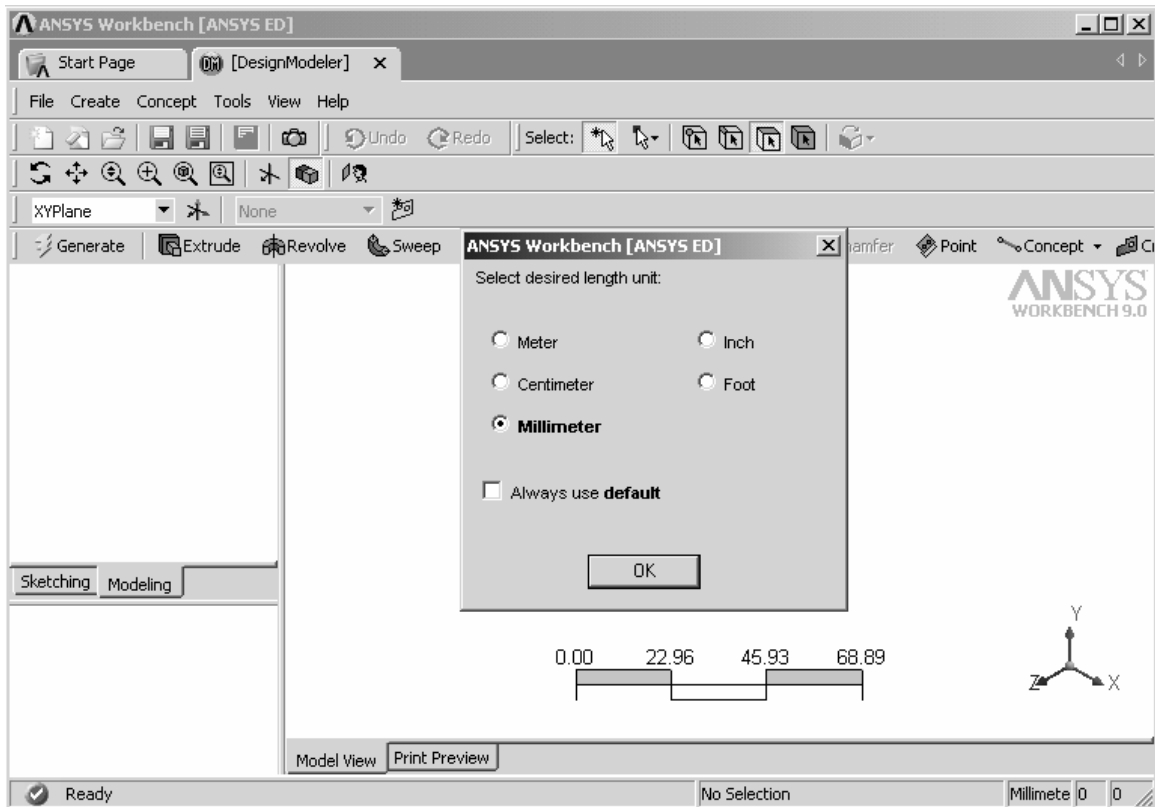

Figure 1-4 DesignModeler interface.

3. **Select OK** – To work in millimeter units.

We will sketch the L-shaped cross section on the XY Plane. Make it **35 mm high, 20 mm wide** with **5 mm thick legs**.

4. **Select XYPlane** as in the figure below. Then **click** on the **Look at icon** to view the XYPlane.

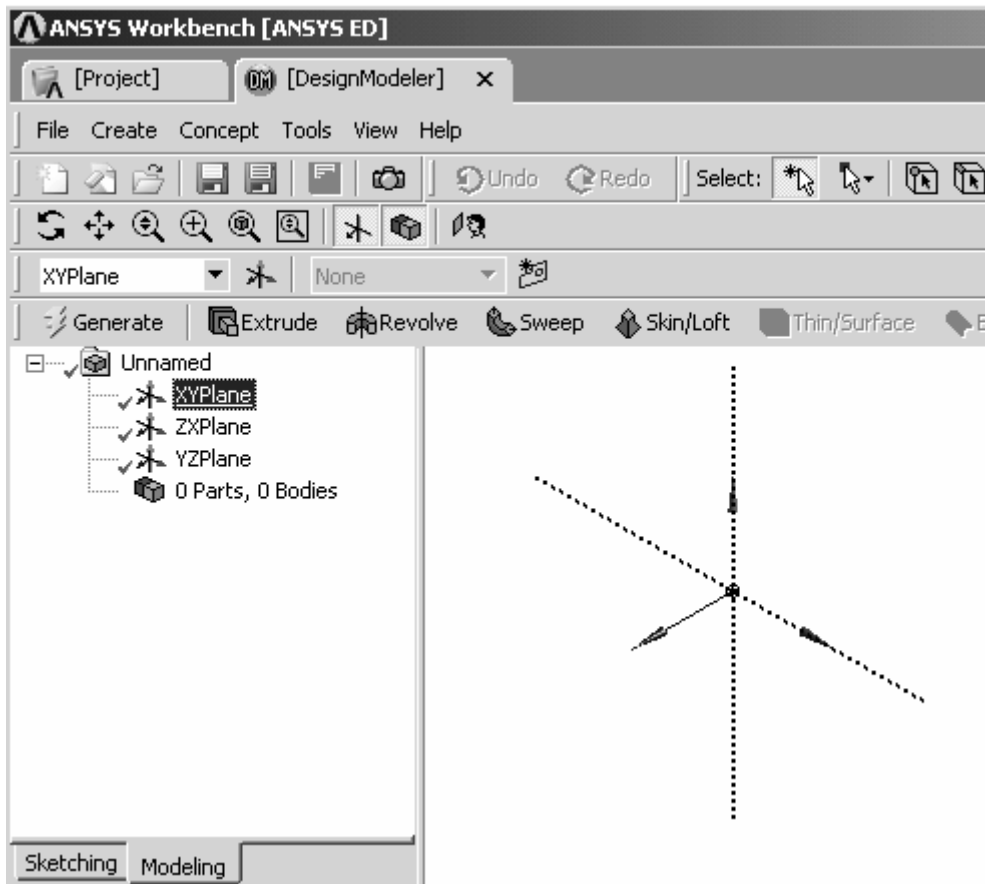

Figure 1-5 Select the sketching plane.

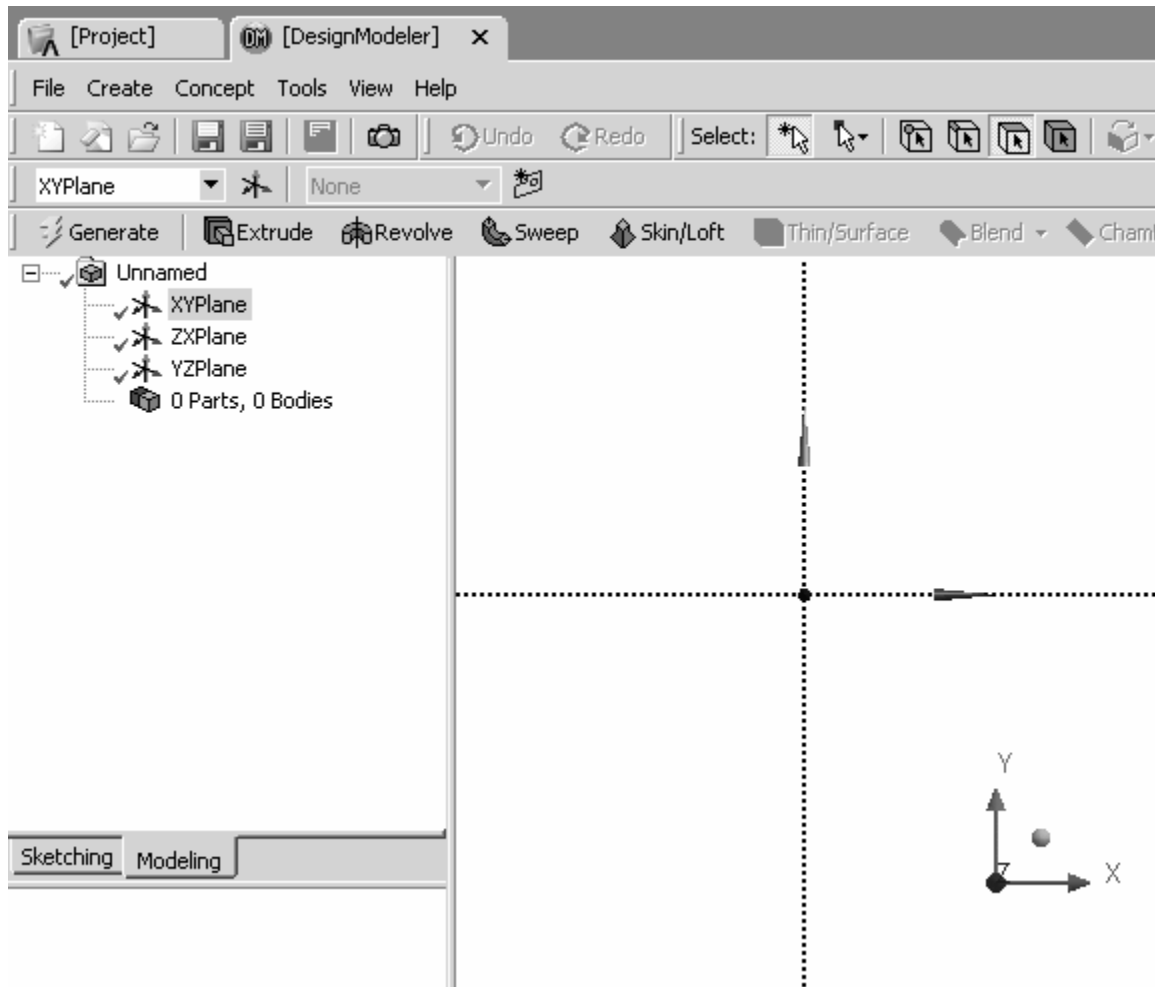

Figure 1-6 View of the sketching plane.

- 5. Sketching.** Change from Modeling to Sketching by selecting the Sketching tab.

Select **Draw > Line**

Figure 1-7 Sketching tools.

- 6. Use the line drawing tool to draw the left vertical edge of the L-shape.** Left click at the beginning and again at the end of the line. The **V** indicates that you've got it exactly **vertical**.

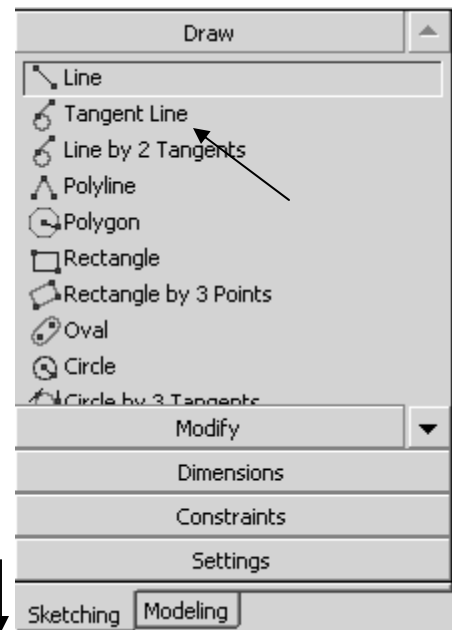

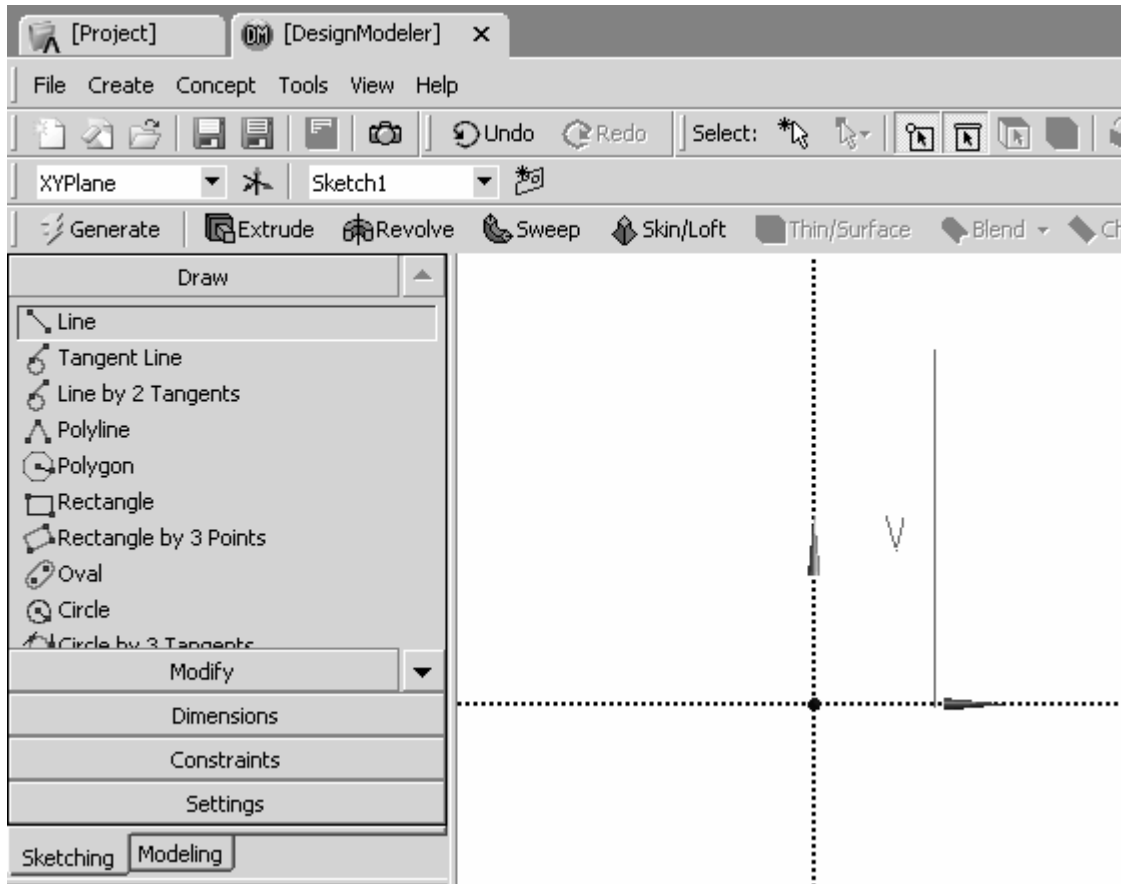

Figure 1-8 Left edge of the L-shape.

7. **Continue sketching** until you have something like what is shown below. (Notice that the top edge is not quite horizontal.) If you need to change something, use the **New Selection, Edge** filter to select the line, press the delete key and redraw it. Also note that the cursor changes shape when it is snapped onto another point or axis.

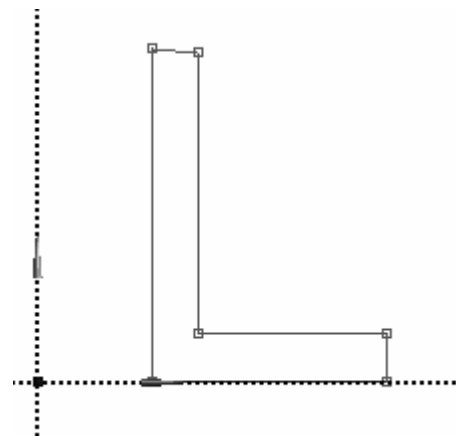

Figure 1-9 L-section sketch.

Now use constraint options to make the top edge horizontal and to make sure that the vertical and horizontal legs of the L are of the same thickness.

8. Sketching > Constraints > Horizontal –

Left click the top edge.

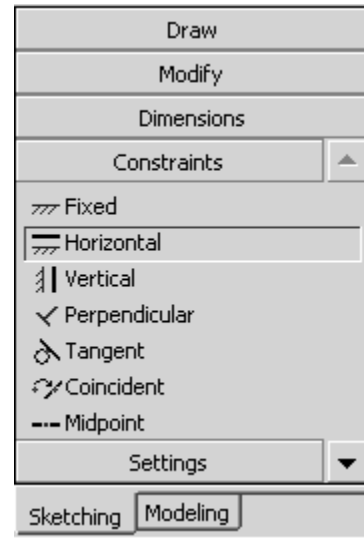

Figure 1-10 Sketching constraints.

9. Sketching > Constraints > Equal length –

Left Click the top edge and then the right edge.

The figure is just a sketch so far, and a number of different dimensioning schemes could be used to produce the section we want. We will use the **Sketching > Dimensions** options to give it the desired properties.

10. Sketching > Dimensions > General – Left click on the left vertical edge of the section and drag the dimension to a convenient location. The V1 means this is the first vertical dimension for this sketch.

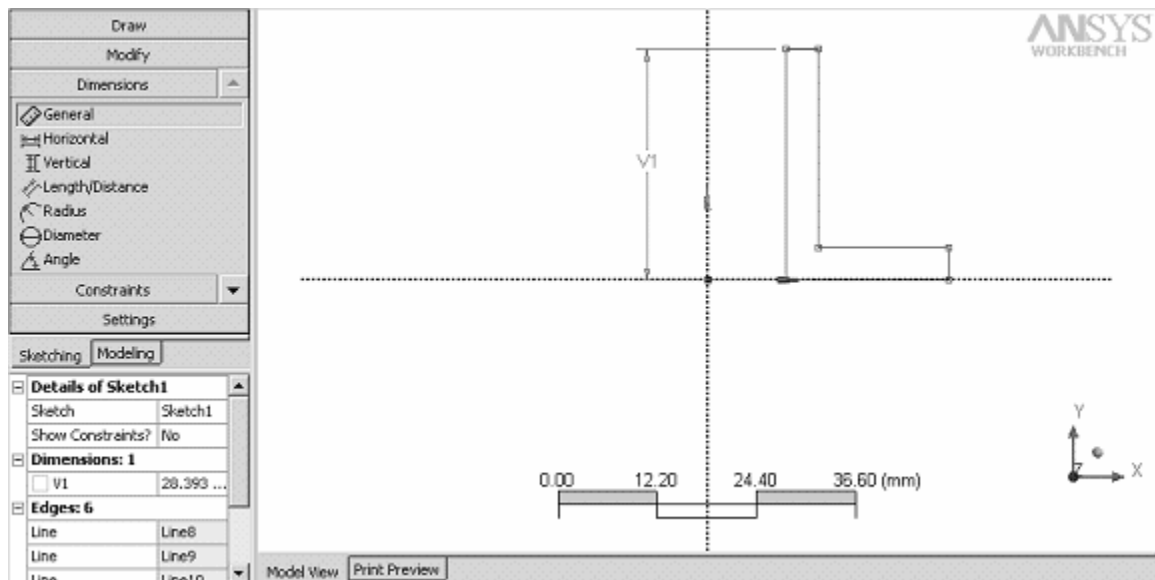

Figure 1-11 L-section sketch.

Continue with General dimensioning to specify H2 and V4. Don't dimension the top edge; it has to be equal to V4. The bottom edge is located directly on the X axis but we need to locate the vertical edge with respect to the Y axis.

11. **Sketching > Dimensions > Horizontal** – Left click the left vertical edge then click the dotted Y axis and drag the H3 dimension to a convenient location.

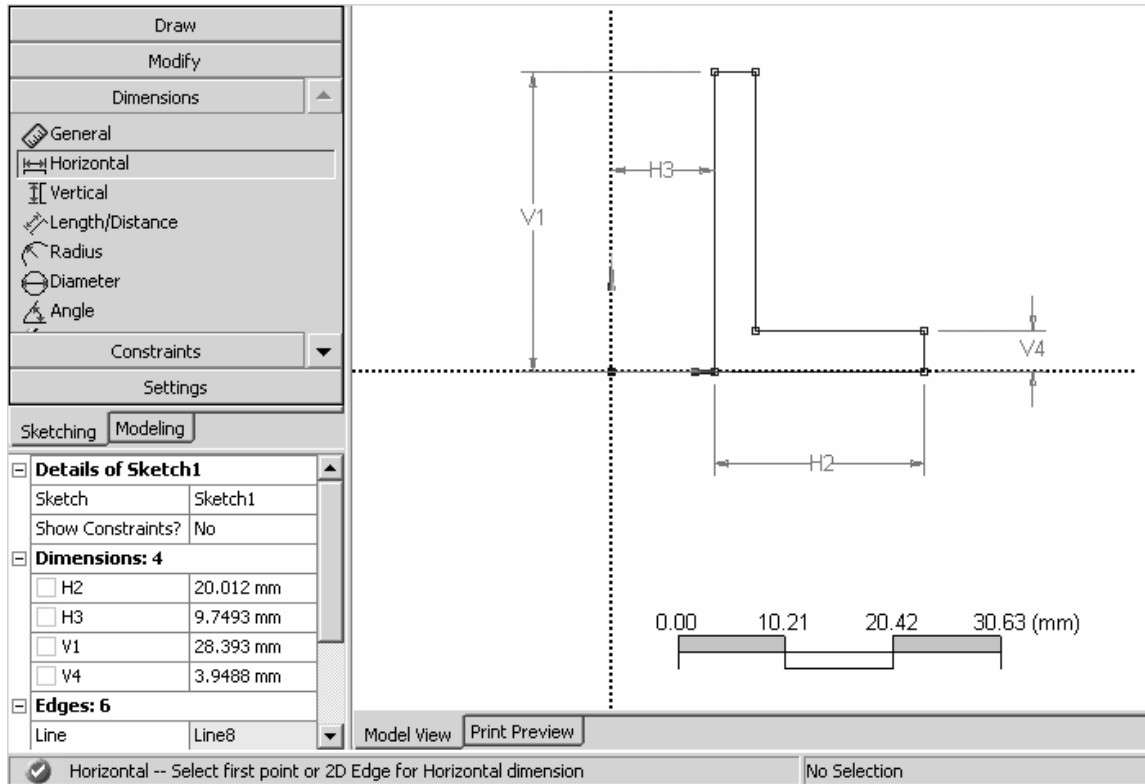
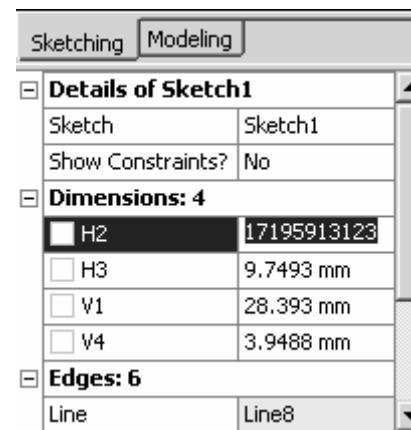

Figure 1-12 L-section sketch with all dimensions.

The current values for the dimensions depend upon the scale used in the sketching process, e.g., H2 = 20.012 mm in the figure above.

12. **Edit the dimensions to give them the desired values.** – Click on a value, enter the change and press return.

Figure 1-13 Default dimension values.



13. **View > Ruler** (Top menu) to turn off the ruler display. Use the middle mouse roller to zoom in and out.

The result is shown in the figure below.

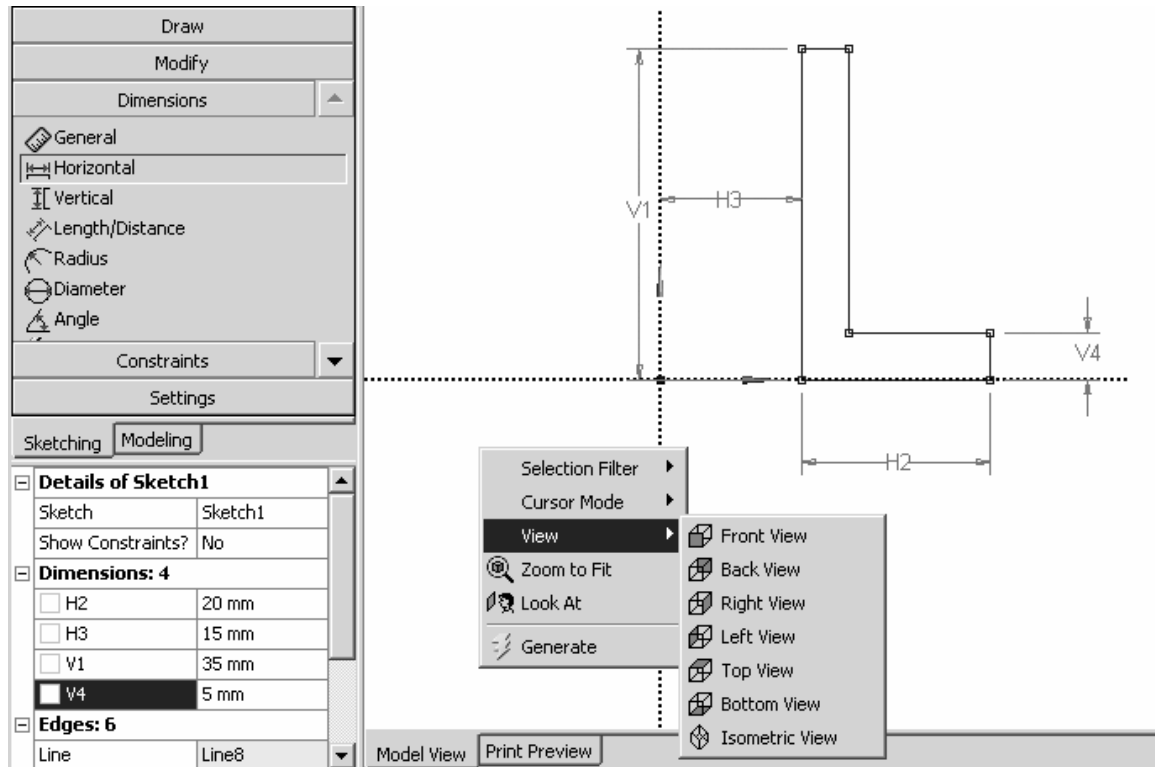

Figure 1-14 Edited dimension values.

To reposition the section on the screen, **Right Click** and select one of the following options: **Cursor Mode**, **View**, or **Zoom to Fit**.

To perform the extrusion, switch from Sketching to Modeling. If is not already highlighted, click **Sketch1** to highlight it.

14. **Modeling > Sketch1 > Extrude** 

The L-shaped section will be extruded along the positive Z axis by the amount specified in the **Depth** field shown in the next figure. **Edit this value** (45 mm) to give the solid a **depth** of **100 mm**.

The tree structure shows the components from which the solid model is created.

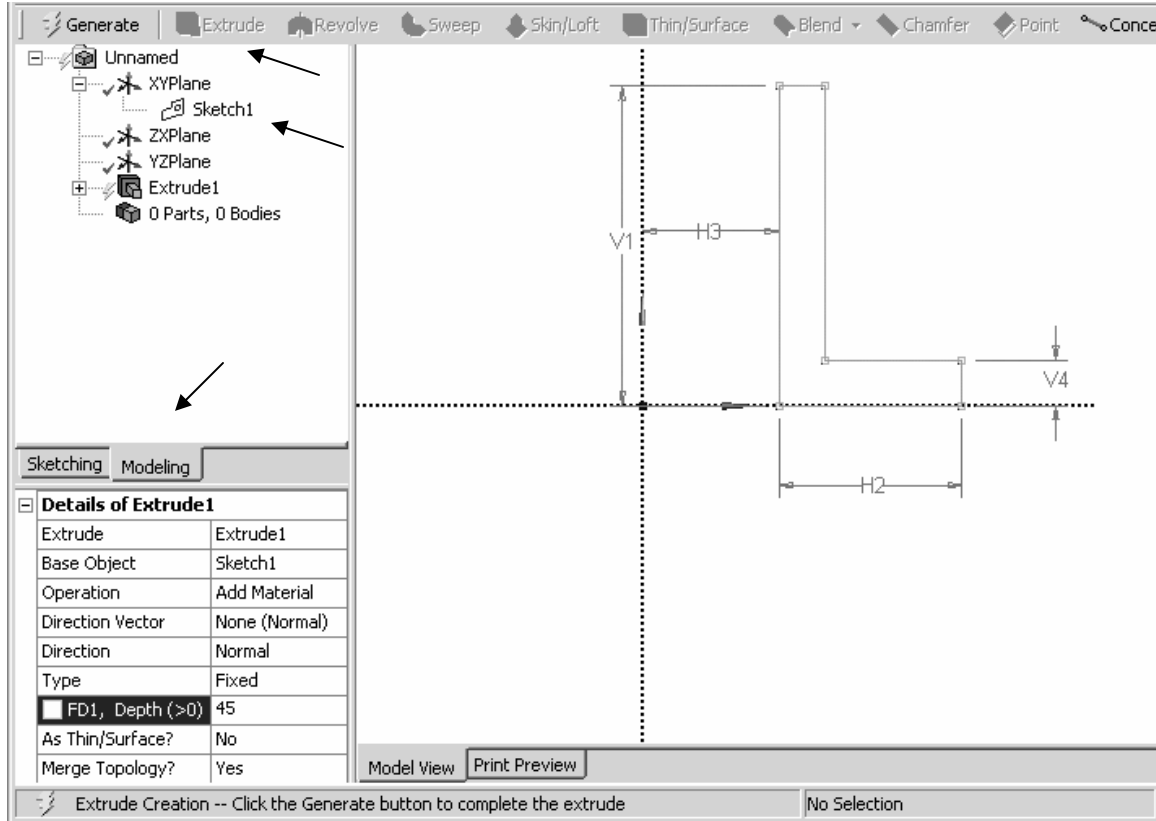
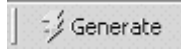

Figure 1-15 Section ready for extrusion.

15. Click the **Generate** icon to complete creation of the extruded shape model.



Right click > View > Isometric (or hold down the middle mouse button and rotate the object).

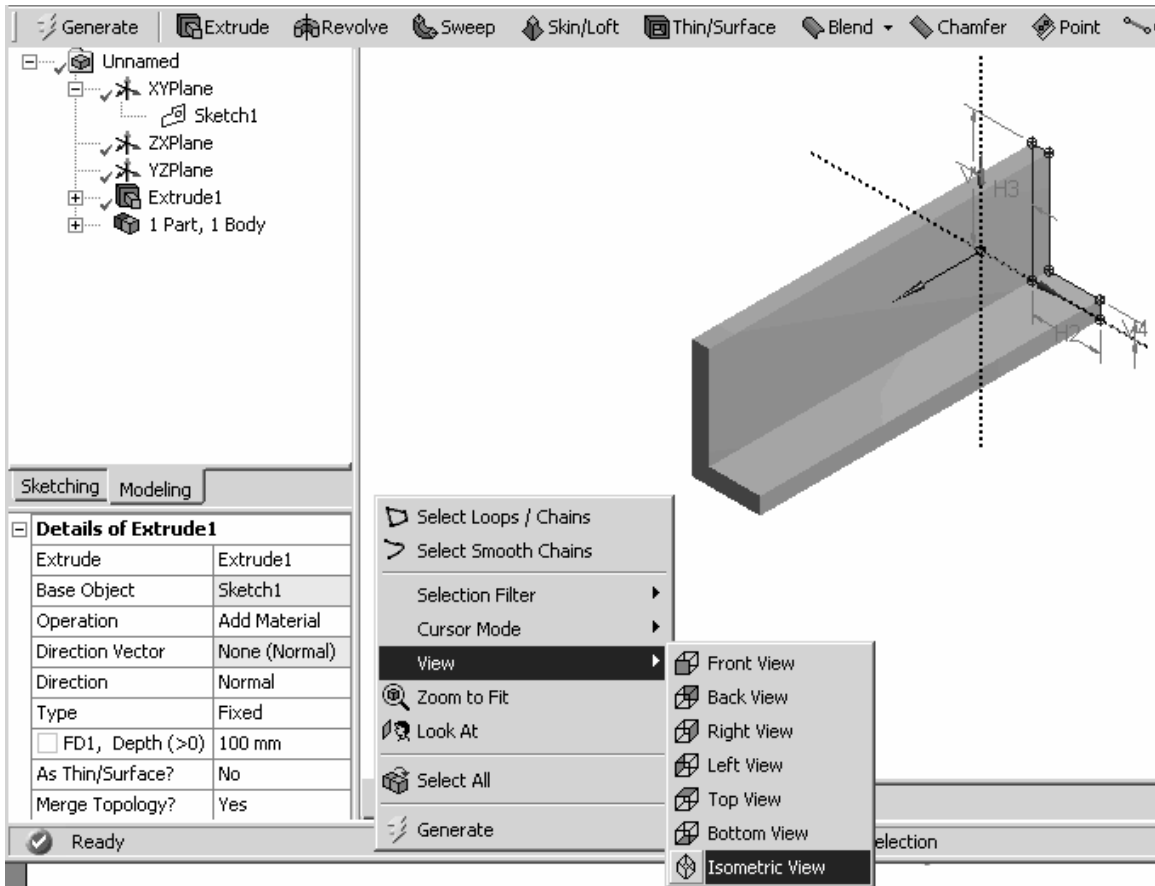



Figure 1-16 Extrusion.

16. Click on the **Display Plane** icon  to turn off the axes display and high-light the last item in the model tree (Solid) to display the volume, surface area, faces, edges and vertices in this model.

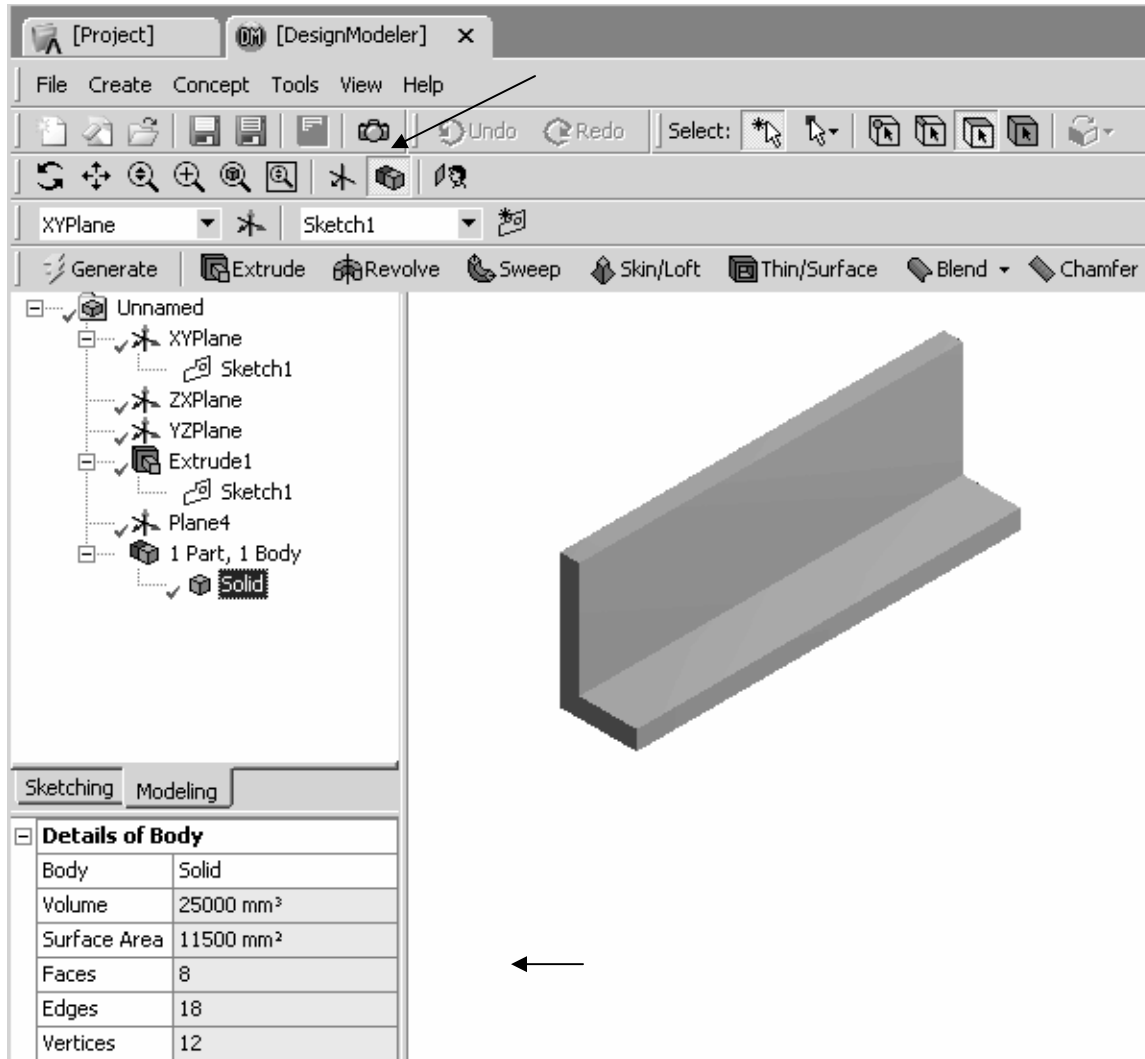

Figure 1-17 Solid and its properties.

17. **Save your work** – Use the **Save As** option to save the extrusion using a name (e.g. T1A) and location of your choice.

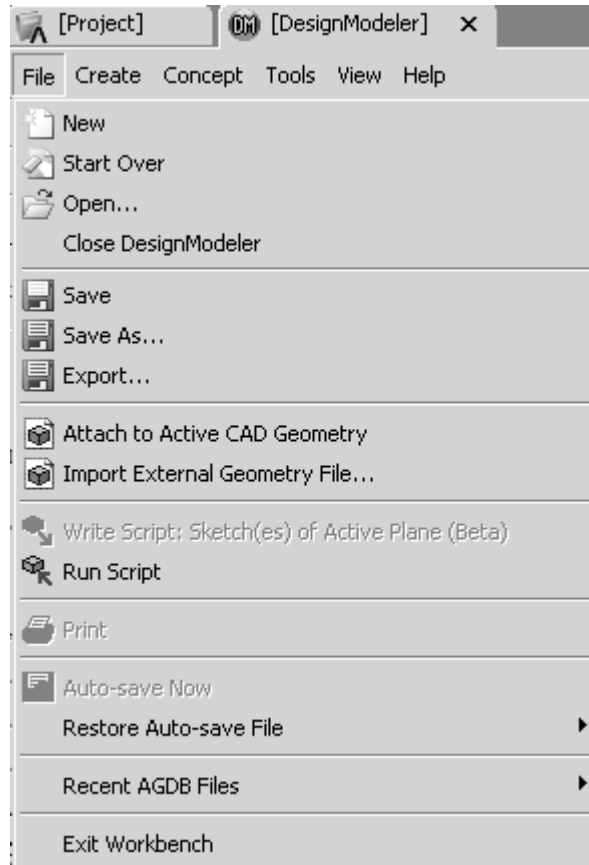

Figure 1-18 File menu.

Basic solid modeling notions have been used thus far to demonstrate creating a solid by extruding a two-dimensional section. In the next tutorial we will revolve the same L-shape to create a solid of revolution.

1-4 TUTORIAL 1B – REVOLUTION

We can reuse the extrusion model after it has been safely saved somewhere. Start from the screen shown below if the extrusion is still in memory, or start Workbench and reload the extrusion.

First modify the tree structure.

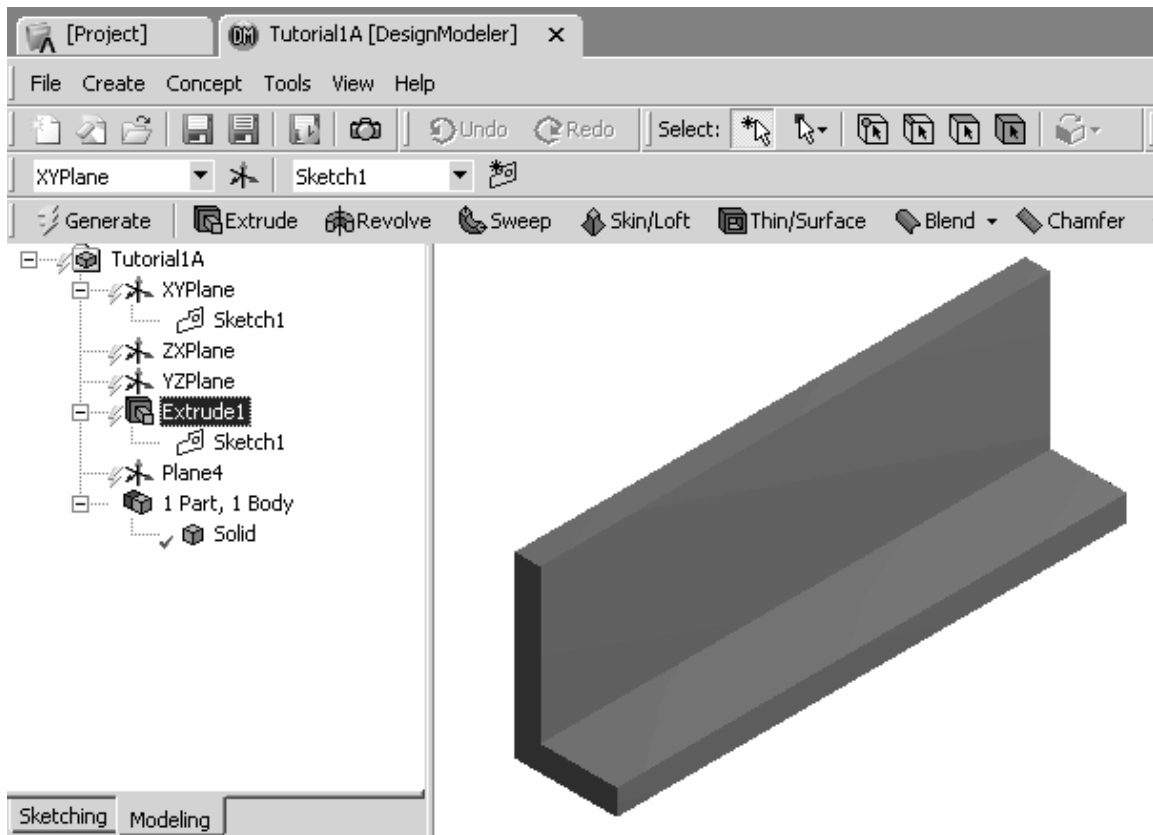

Figure 1-19 Select the extrusion.

1. Click on **Extrude1** and **press Delete**. Click **Yes** to the query. The extrusion is deleted and the new tree structure shows 0 Parts and 0 Bodies.

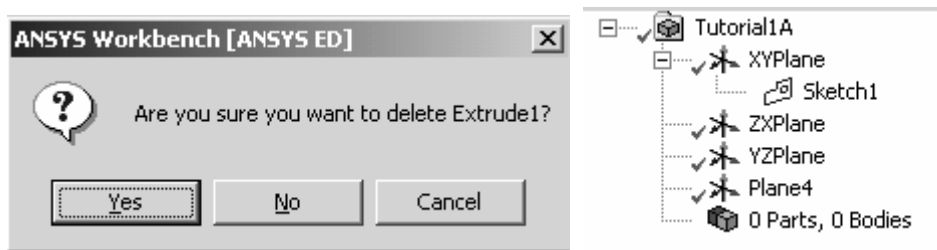



Figure 1-20 Delete the extrusion.

2. Use **Save As** to save this work using a **new file name**, say **Tutorial1B**.

3. Click on **Sketch1**, the **Display Plane** icon  and the **Look at Plane** icon .

We obtain the view of the same sketch we had earlier.

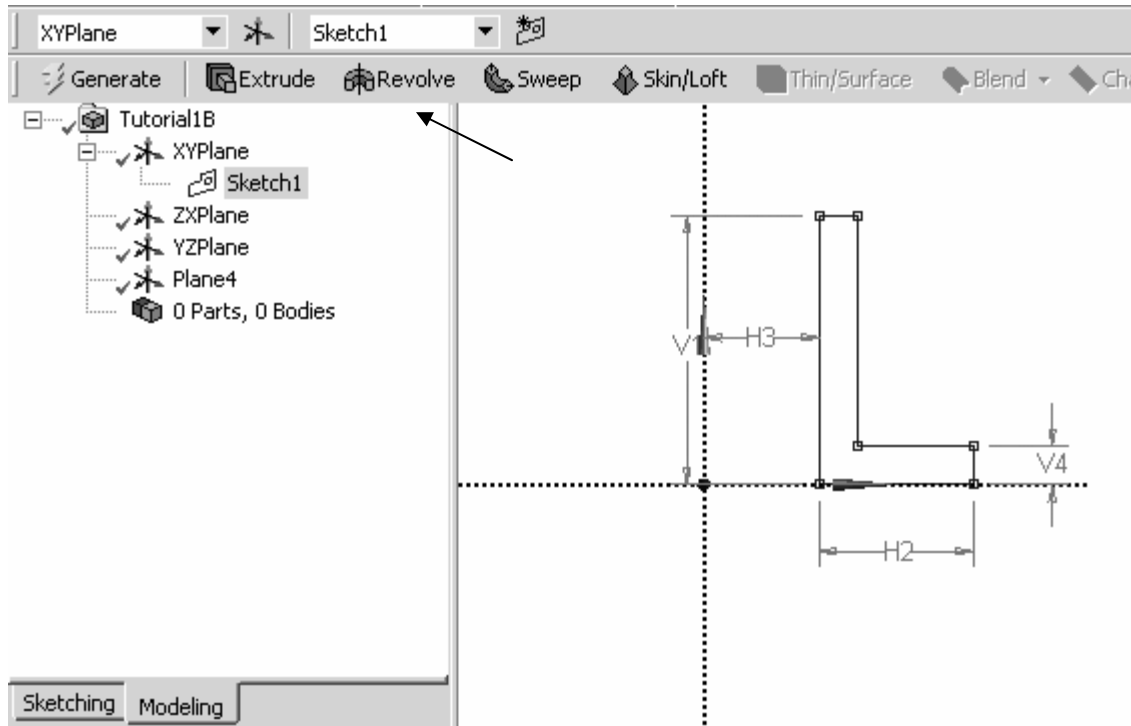
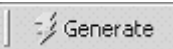

Figure 1-21 Select the sketch.

4. Be sure **Sketch1** is highlighted and Click **Revolve**.
5. Click **Axis** > **Select the Y axis** > **Apply** (below right)
6. **Select Angle** > **Enter 120 deg.**
7. **Click Generate** 

The L-shaped section is rotated about the Y axis by 120 degrees using a right-hand rule to create the solid of revolution shown next.

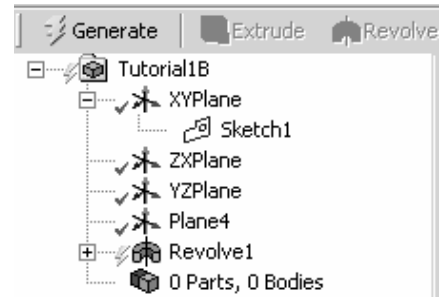
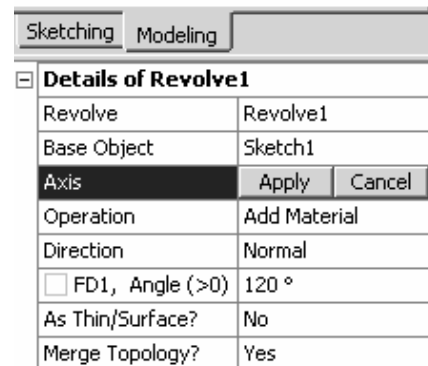

Figure 1-22 Revolve1 tree.



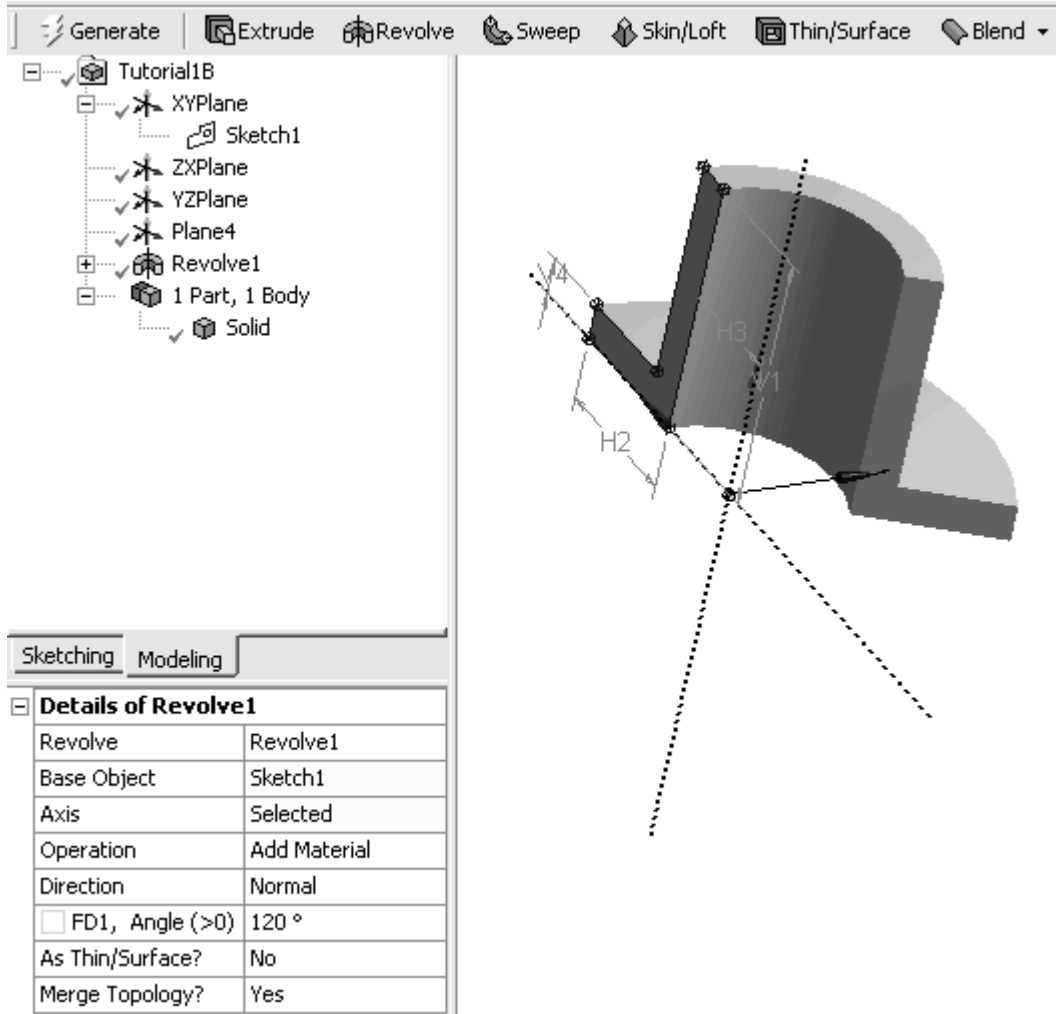

Figure 1-23 Solid of revolution.

8. Save to archive your work.

Next we will take the same cross section and sweep it along an arbitrary path to create the third kind of modeling discussed in this chapter.

1-5 TUTORIAL 1C – SWEEP

- 1. Start ANSYS Workbench. Sketch the 20 x 35 mm L-shape on the XYPlane as before.** We get the figure shown below. Save this file as tutorial1c or T1C or something convenient.

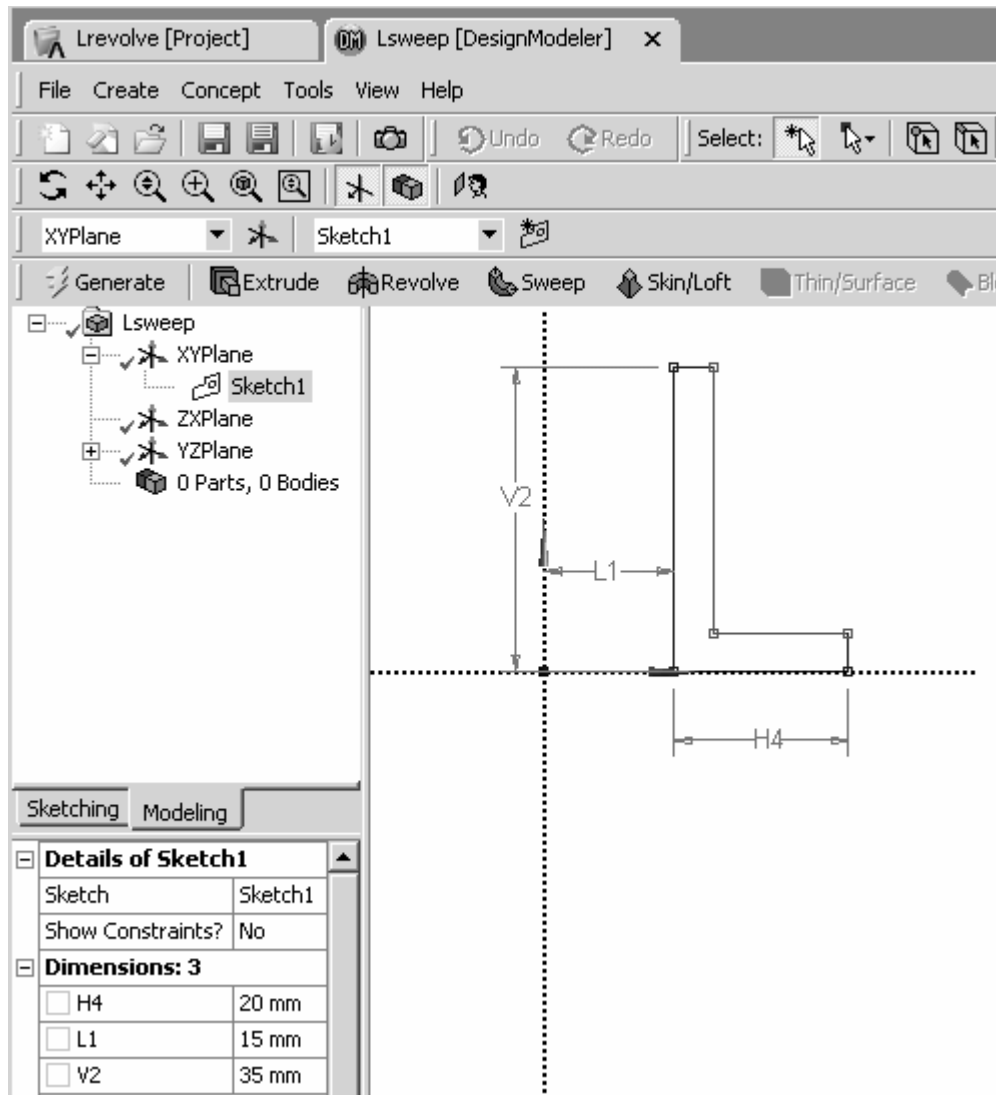
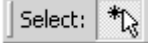

Figure 1-24 Cross section sketch.

We now want to sketch a path along which the L-shape will be swept to produce a solid. We will use a simple curve to define this path.

- 2. Select the YZPlane and Select Sketching.**
- 3. Use the Line option to sketch a simple two-segment line in the YZPlane similar to the one below.**

Turn on the **Ruler** and use the **middle scroll wheel** to **Zoom** out so that your line is about 150 to 200 mm in length. If you make a mistake, click the New Select button , click the line and press delete. (I deleted several before settling on the one shown, so my sketch is numbered Sketch6. Not to worry if your number is different.)

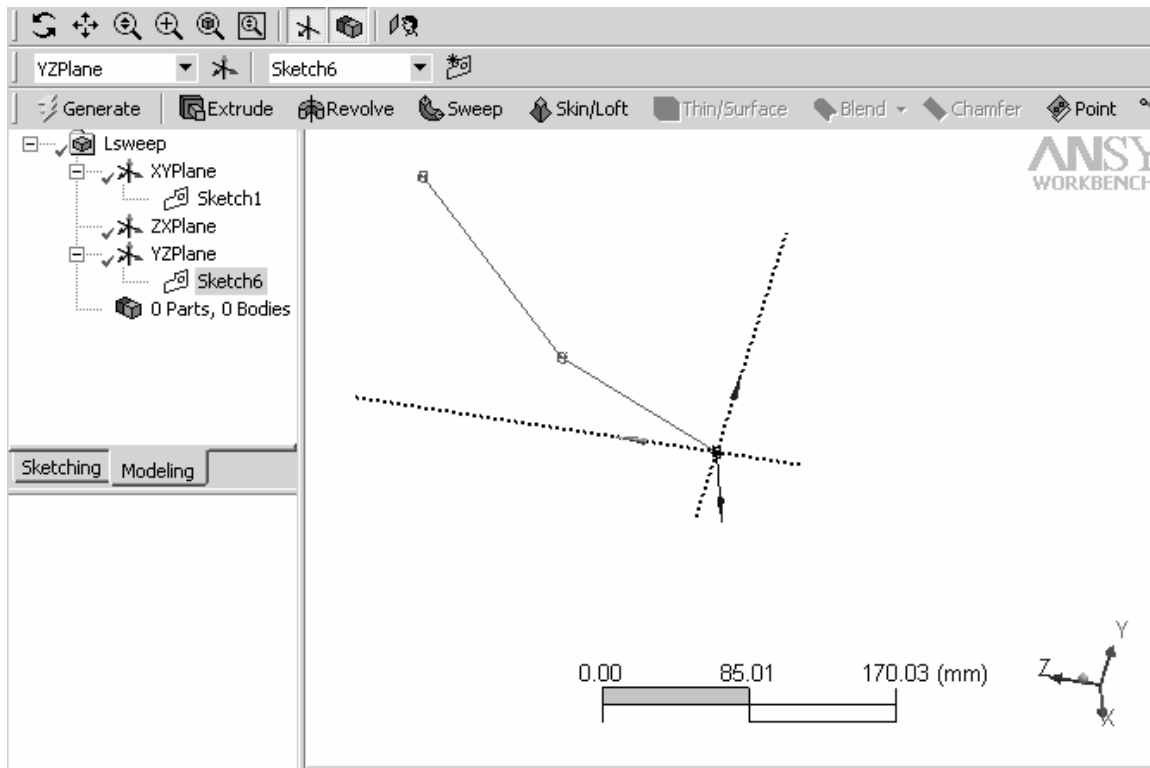
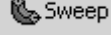

Figure 1-25 Path of sweep.

4. **Select Sweep** to create the solid. 

We need to specify the **Profile** (cross section) of the solid and the **Path** along which the profile will be swept.

5. Click **Sketch1** > **Details of Sweep1** > Click on **Profile** > **Apply**.
6. Click **Sketch6** > **Details of Sweep1** > **Path** > **Apply** (Sketch6 in the figure above. Your path sketch number will be different.)

See the figure below.

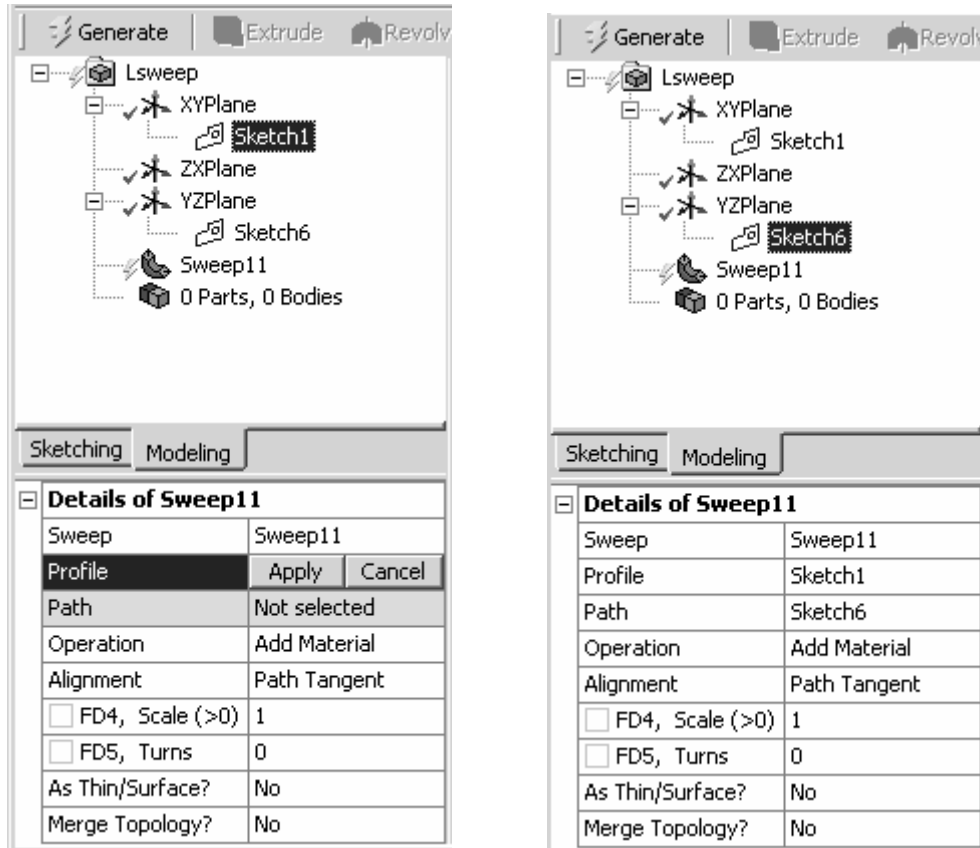
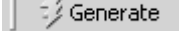

Figure 1-26 Profile and path selection.

7. **Generate** to obtain the solid shown next. 

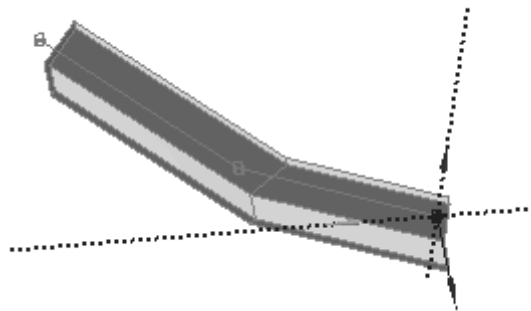

Figure 1-27 Swept solid.

Notice that the profile is not necessarily perpendicular to the path as when we used Extrude to create a solid. Also the path can be a more complex curve as in the example of Figure 1-1 where a spline was used for the path.

1-6 SKETCHING

A wide variety of sketching tools are available to help in creating two-dimensional sections. We used the line drawing option and the equality constraint option in the tutorials above. Some of the other sketching features are shown below.

The next illustration shows the **Draw** and **Modify** options. The **Draw** menu includes **Line**, **Tangent Line**, **Line by two Tangents**, **Polyline**, **Polygon**, **Rectangle**, **Oval**, **Circle**, **Arc**, **Ellipse**, **Spline** and **Construction Point**.

The **Modify** menu includes **Fillet**, **Chamfer**, **Trim**, **Extend**, **Split**, **Drag**, **Cut**, **Copy**, **Paste**, **Move**, **Replicate** and **Offset**.

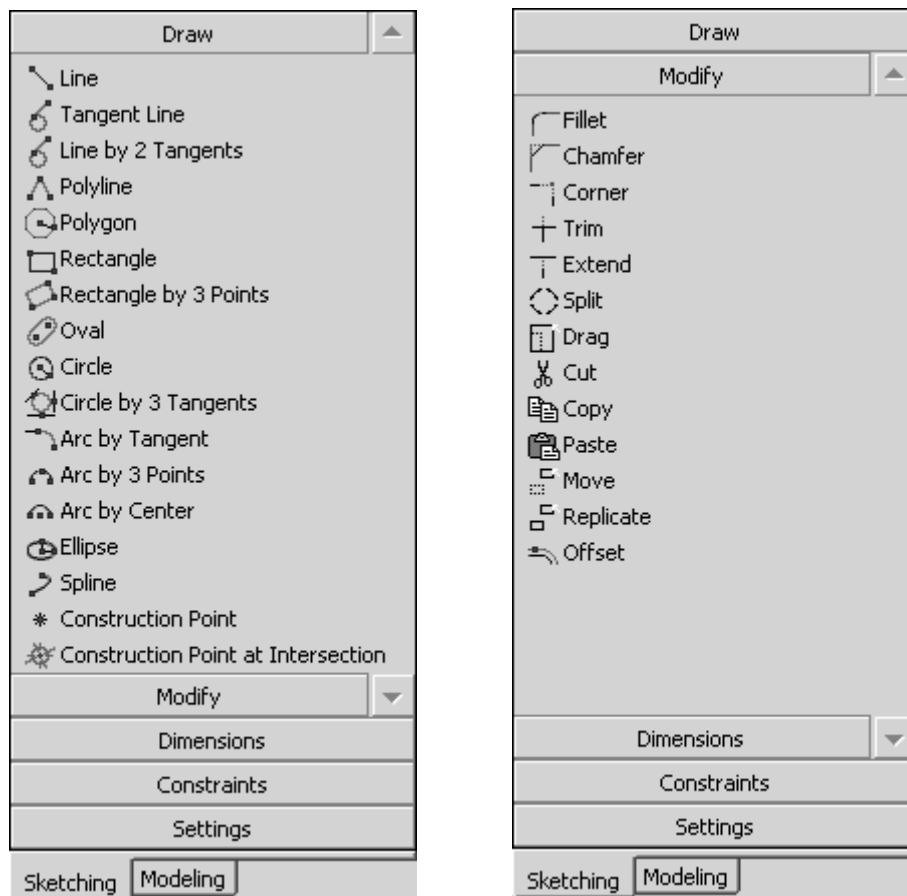

Figure 1-28 Draw and Modify sketching options.

We will have the occasion to illustrate the use of many of these options in what follows.

Menu selections for assigning **Dimensions** and enforcing **Constraints** are shown in the next figure.

In addition to a **General** dimension specification, Dimensions can be assigned which are **Horizontal**, **Vertical**, **Length/Distance**, **Radius/Diameter**, or an **Angle**. Select **Semi-Automatic Dimensioning** if you want DesignModeler to select a dimensioning scheme automatically. You then have the option to accept, add or delete dimensions to meet your specific design needs.

Constraints that can be enforced for sketching entities include **Horizontal**, **Vertical**, **Perpendicular**, **Tangent**, **Coincident**, **Midpoint**, **Symmetric**, **Parallel**, **Concentric**, **Equal Radius**, **Equal Length** and **Equal Distance**.

As sketching proceeds DesignModeler will attempt to detect and enforce constraints that seem to be part of the design intent of the sketch. The **Auto Constraints** option allows you to turn these on and off as desired. **Cursor** triggered constraints are local, while **Global** constraints relate to all entities in the sketching plane.

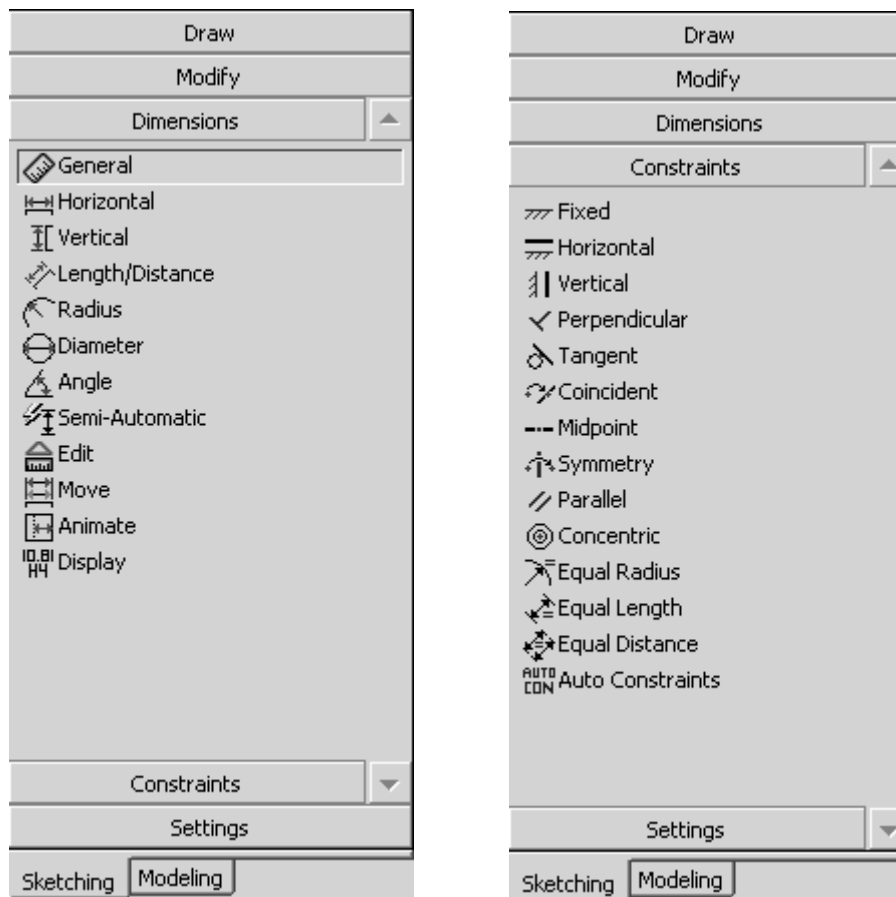

Figure 1-29 Dimension and Constraint sketching options.

Dimensioning is the process of defining how geometry is to be constructed.

In that regard, sketches must be **unambiguously** defined; that is, they cannot have too many dimensions or too few dimensions specified. The figure below shows two different dimensioning schemes for a simple shape.

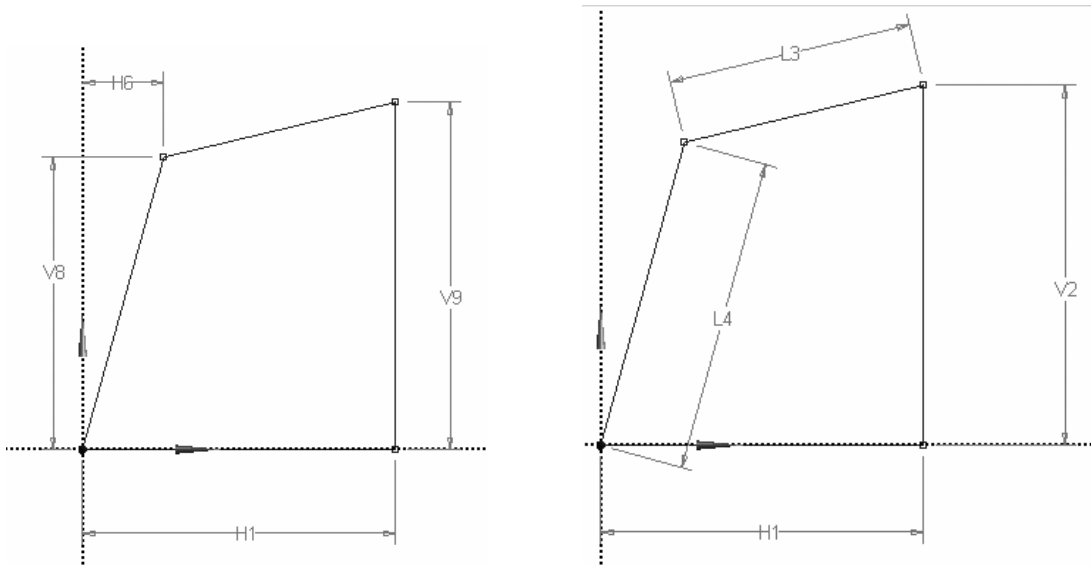

Figure 1-30 Dimensioning schemes.

If you over dimension a sketch, DesignModeler will issue the following warning:

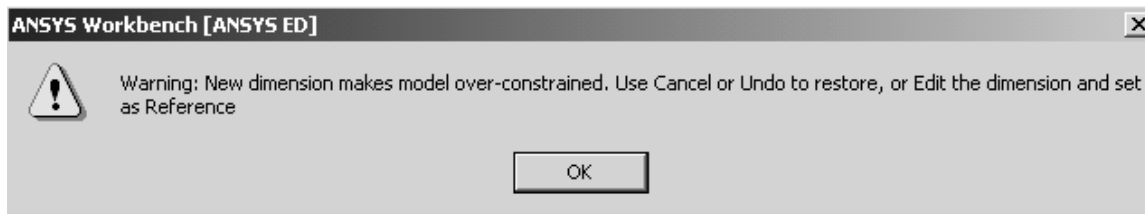

Figure 1-31 Over-constraint message.

Finally, the **Settings** option provides a **grid** sketching aid that allows you create drawing entities placed at vertices of the grid as indicated in the next figure.

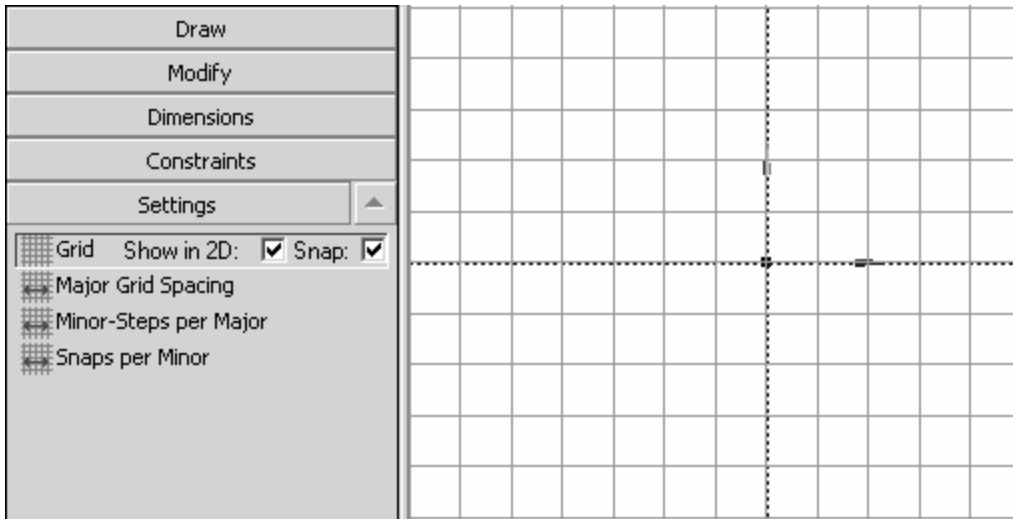

Figure 1-32 Settings options and a sketching grid.

1-7 SUMMARY

Three tutorials in Chapter 1 introduce basic solid model creation in ANSYS DesignModeler and provide examples from which more complex shapes can be developed. In the next chapter we will extend these ideas and introduce additional modeling features.

1-8 PROBLEMS

- 1-1 Identify some common objects (such as an unsharpened pencil, drinking glass, etc.) and develop models of them using the ideas presented in this chapter.
- 1-2 Use a “Z” shaped section to create a solid by extrusion, another by revolving, and another by sweeping. Select your own units and dimensions.
- 1-3 Measure the exterior dimensions of a light bulb, estimate the wall thickness of the glass and base, and create a model by revolving the sketch.
- 1-4 Create the shape shown and extrude it to form a solid. Choose your own dimensions. Use the Sketching **Trim** option to help in the sketch development. Save it and we’ll use it in a simulation problem later in the text.



Figure P1-4

NOTES:
