

Parametric Modeling With Autodesk Inventor® R9

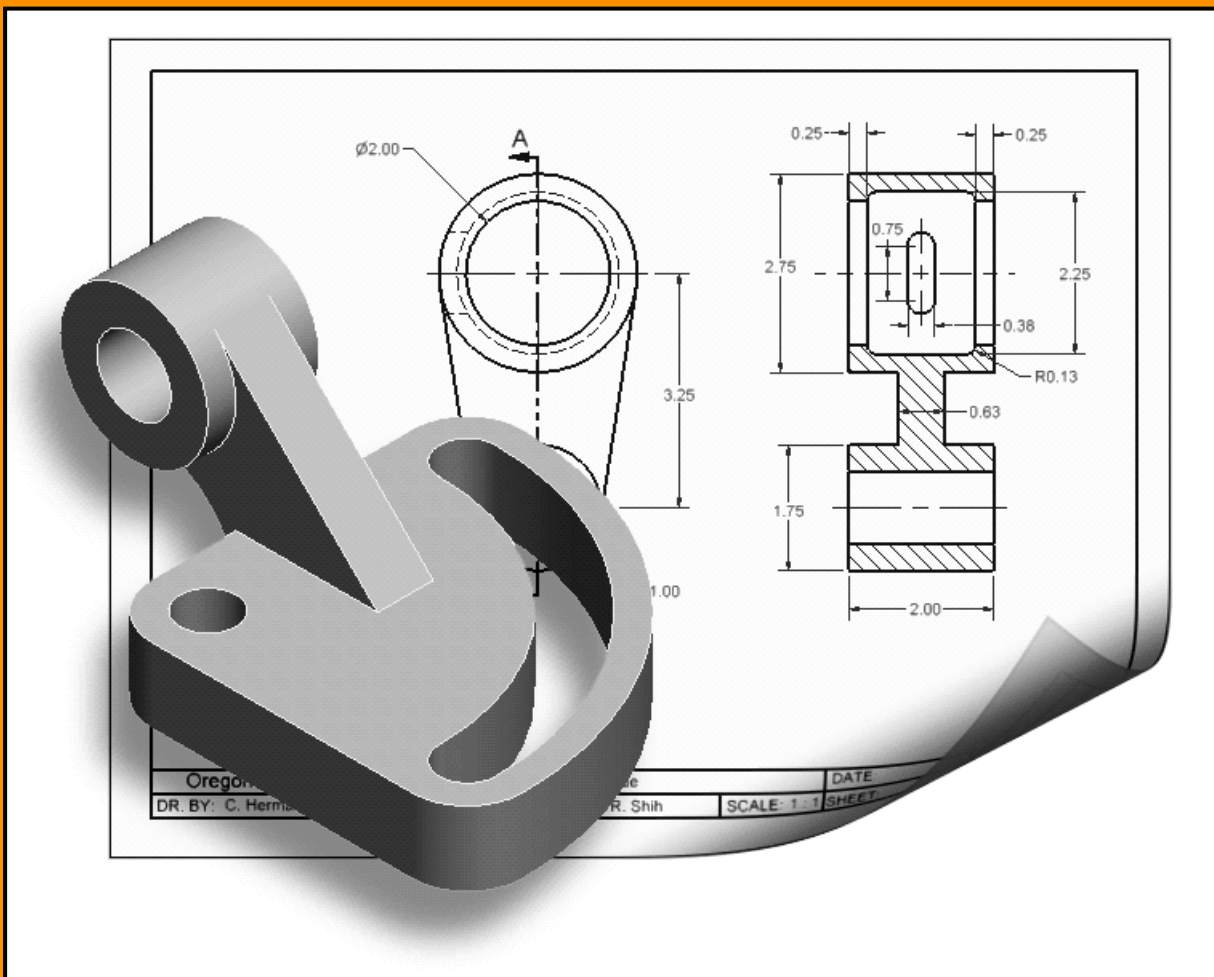

Randy H. Shih
Oregon Institute of Technology

SDC
PUBLICATIONS

Schroff Development Corporation

www.schroff.com
www.schroff-europe.com

Chapter 2

Parametric Modeling Fundamentals

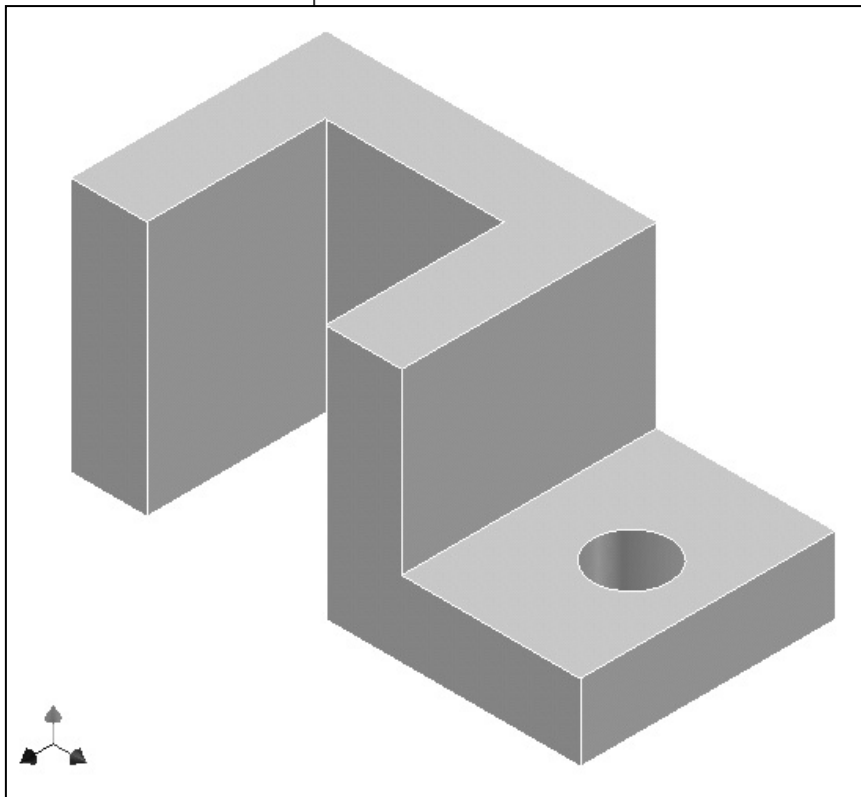

Learning Objectives

- ◆ Create Simple Extruded Solid Models
- ◆ Understand the Basic Parametric Modeling Procedure
- ◆ Create 2-D Sketches
- ◆ Understand the "Shape before size" Approach
- ◆ Use the Dynamic Viewing Commands
- ◆ Create and Edit Parametric Dimensions

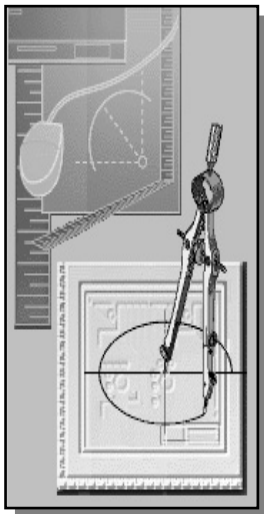

Introduction

The **feature-based parametric modeling** technique enables the designer to incorporate the original **design intent** into the construction of the model. The word *parametric* means the geometric definitions of the design, such as dimensions, can be varied at any time in the design process. Parametric modeling is accomplished by identifying and creating the key features of the design with the aid of computer software. The design variables, described in the sketches and described as parametric relations, can then be used to quickly modify/update the design.

In *Autodesk Inventor*, the parametric part modeling process involves the following steps:

1. **Create a rough two-dimensional sketch of the basic shape of the base feature of the design.**
2. **Apply/modify constraints and dimensions to the two-dimensional sketch.**
3. **Extrude, revolve, or sweep the parametric two-dimensional sketch to create the base solid feature of the design.**
4. **Add additional parametric features by identifying feature relations and complete the design.**
5. **Perform analyses on the computer model and refine the design as needed.**
6. **Create the desired drawing views to document the design.**

The approach of creating two-dimensional sketches of the three-dimensional features is an effective way to construct solid models. Many designs are in fact the same shape in one direction. Computer input and output devices we use today are largely two-dimensional in nature, which makes this modeling technique quite practical. This method also conforms to the design process that helps the designer with conceptual design along with the capability to capture the *design intent*. Most engineers and designers can relate to the experience of making rough sketches on restaurant napkins to convey conceptual design ideas. *Autodesk Inventor* provides many powerful modeling and design-tools, and there are many different approaches to accomplishing modeling tasks. The basic principle of **feature-based modeling** is to build models by adding simple features one at a time. In this chapter, the general parametric part modeling procedure is illustrated; a very simple solid model with extruded features is used to introduce the *Autodesk Inventor* user interface. The display viewing functions and the basic two-dimensional sketching tools are also demonstrated.

The *Adjuster* Design

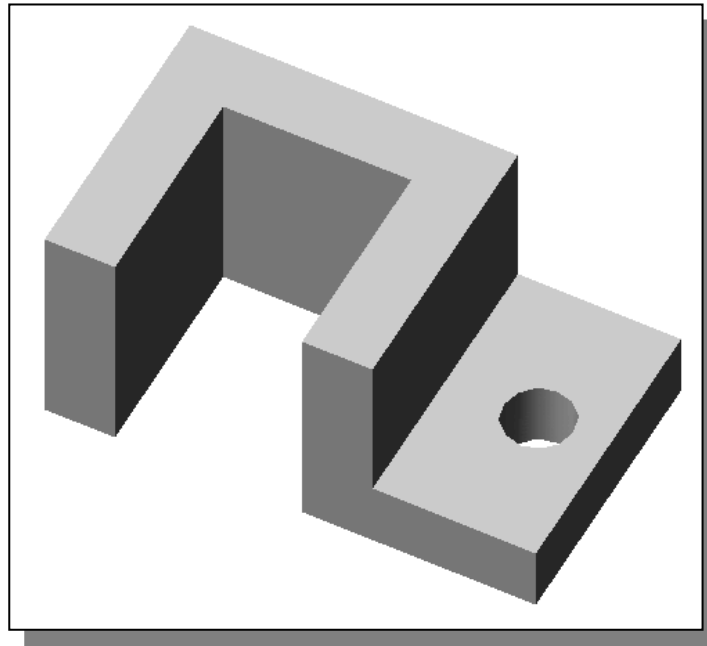

Starting *Autodesk Inventor*

1. Select the **Autodesk Inventor** option on the *Start* menu or select the **Autodesk Inventor** icon on the desktop to start *Autodesk Inventor*. The *Autodesk Inventor* main window will appear on the screen.

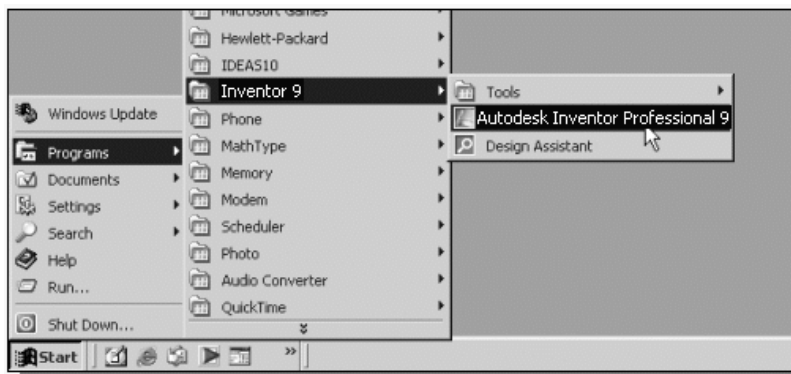

2. Select the **New** icon with a single click of the left-mouse-button in the *What to Do* dialog box.

3. Select the **English** tab as shown below. When starting a new CAD file, the first thing we should do is choose the units we would like to use. We will use the English setting (inches) for this example.

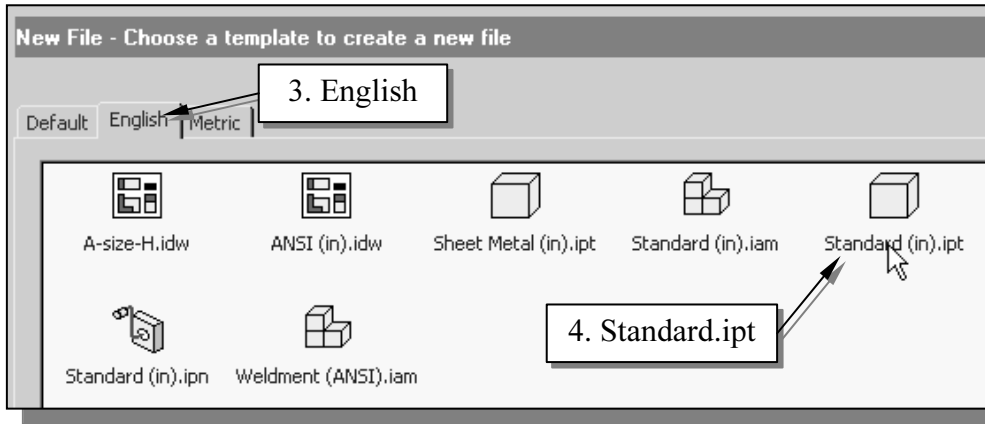

4. In the *New - Choose Template* area, select the **Standard(in).ipt** icon as shown.
5. Pick **OK** in the *Startup* dialog box to accept the selected settings.

Autodesk Inventor Screen Layout

- The default *Autodesk Inventor* drawing screen contains the *pull-down* menus, the *Standard* toolbar, the *Sketch* toolbar, the *graphics* window, the *browser* area, and the *Status Bar*.

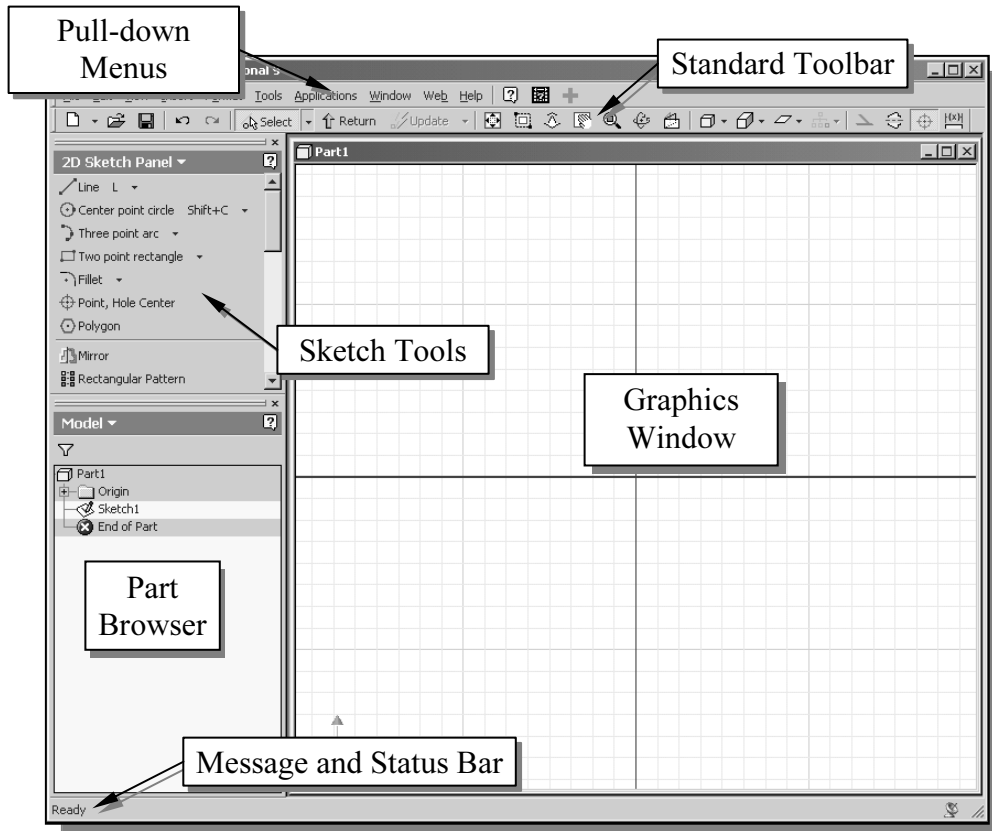

Creating Rough Sketches

Quite often during the early design stage, the shape of a design may not have any precise dimensions. Most conventional CAD systems require the user to input the precise lengths and locations of all geometric entities defining the design, which are not available during the early design stage. With *parametric modeling*, we can use the computer to elaborate and formulate the design idea further during the initial design stage. With *Autodesk Inventor*, we can use the computer as an electronic sketchpad to help us concentrate on the formulation of forms and shapes for the design. This approach is the main advantage of *parametric modeling* over conventional solid-modeling techniques.

As the name implies, a **rough sketch** is not precise at all. When sketching, we simply sketch the geometry so that it closely resembles the desired shape. Precise scale or lengths are not needed. *Autodesk Inventor* provides us with many tools to assist us in finalizing sketches. For example, geometric entities such as horizontal and vertical lines are set automatically. However, if the rough sketches are poor, it will require much more work to generate the desired parametric sketches. Here are some general guidelines for creating sketches in *Autodesk Inventor*:

- **Create a sketch that is proportional to the desired shape.** Concentrate on the shapes and forms of the design.
 - **Keep the sketches simple.** Leave out small geometry features such as fillets, rounds and chamfers. They can easily be placed using the **Fillet** and **Chamfer** commands after the parametric sketches have been established.
 - **Exaggerate the geometric features of the desired shape.** For example, if the desired angle is 85 degrees, create an angle that is 50 or 60 degrees. Otherwise, *Autodesk Inventor* might assume the intended angle to be a 90-degree angle.
 - **Draw the geometry so that it does not overlap.** The geometry should eventually form a closed region. *Self-intersecting* geometry shapes are not allowed.
 - **The sketched geometric entities should form a closed region.** To create a solid feature, such as an extruded solid, a closed region is required so that the extruded solid forms a 3D volume.
- **Note:** The concepts and principles involved in *parametric modeling* are very different, and sometimes they are totally opposite, to those of conventional computer aided drafting. In order to understand and fully utilize *Autodesk Inventor*'s functionality, it will be helpful to take a *Zen* approach to learning the topics presented in this text: **Temporarily forget your knowledge and experiences of using conventional Computer Aided Drafting systems.**

Step 1: Creating a Rough Sketch

The *Sketch* toolbar provides tools for creating the basic geometry that can be used to create features and parts.

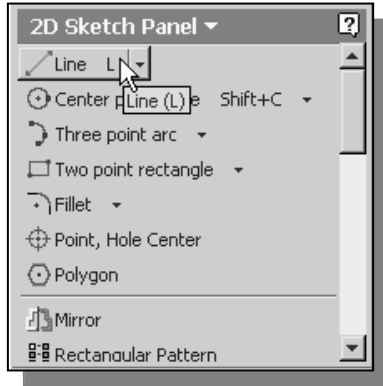

1. Move the graphics cursor to the **Line** icon in the *Sketch* toolbar. A *Help-tip box* appears next to the cursor and a brief description of the command is displayed at the bottom of the drawing screen: “*Creates Straight line segments and tangent arcs.*”
2. Select the icon by clicking once with the **left-mouse-button**; this will activate the **Line** command. In the command prompt area, near the bottom of the *Autodesk Inventor* drawing screen, the message “*Specify start point, drag off endpoint for tangent arcs*” is displayed. *Autodesk Inventor* expects us to identify the starting location of a straight line.

Graphics Cursors

Notice the cursor changes from an arrow to a crosshair when graphical input is expected.

1. Left-click a starting point for the shape, roughly near the lower center of the graphics window as shown below.
2. As you move the graphics cursor, you will see a digital readout in the *Status Bar* area at the bottom of the window. The readout gives you the cursor location, the line length, and the angle of the line measured from horizontal. Move the cursor around and you will notice different symbols appear at different locations.

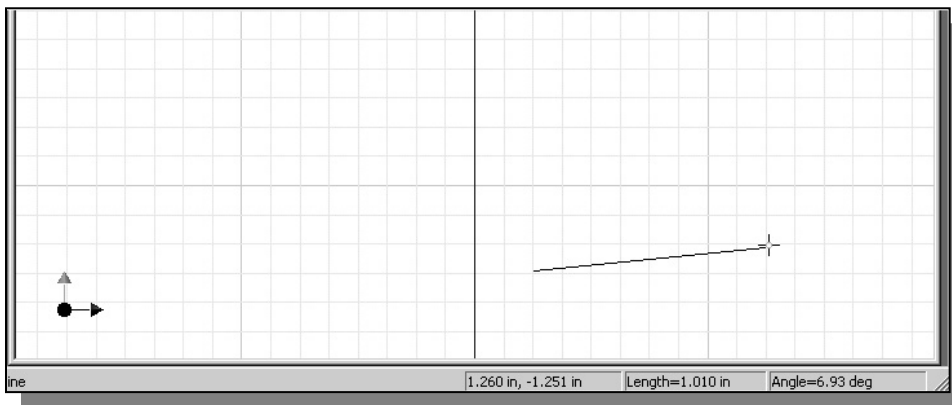

3. Move the graphics cursor toward the right side of the graphics window and create a horizontal line as shown below (**Point 2**). Notice the geometric constraint symbol displayed.

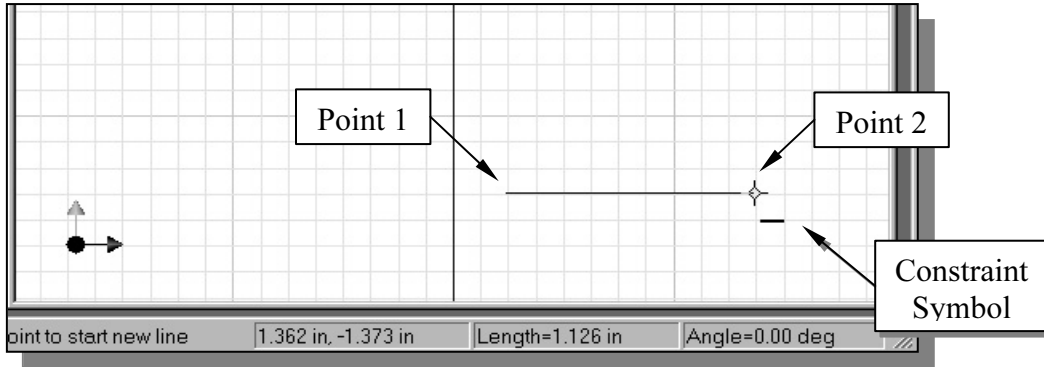

Geometric Constraint Symbols

Autodesk Inventor displays different visual clues, or symbols, to show you alignments, perpendicularities, tangencies, etc. These constraints are used to capture the *design intent* by creating constraints where they are recognized. *Autodesk Inventor* displays the governing geometric rules as models are built. To prevent constraints from forming, hold down the [Ctrl] key while creating an individual sketch curve. For example, while sketching line segments with the **Line** command, endpoints are joined with a *coincident constraint*, but when the [Ctrl] key is pressed and held, the inferred constraint will not be created.

	Vertical	indicates a line is vertical
	Horizontal	indicates a line is horizontal
	Dashed line	indicates the alignment is to the center point or endpoint of an entity
	Parallel	indicates a line is parallel to other entities
	Perpendicular	indicates a line is perpendicular to other entities
	Coincident	indicates the cursor is at the endpoint of an entity
	Concentric	indicates the cursor is at the center of an entity
	Tangent	indicates the cursor is at tangency points to curves

- Complete the sketch as shown below, creating a closed region ending at the starting point (Point 1.) Do not be overly concerned with the actual size of the sketch. Note that all line segments are sketched horizontally or vertically.

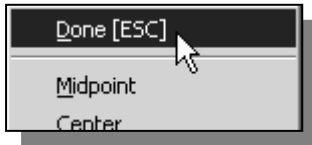
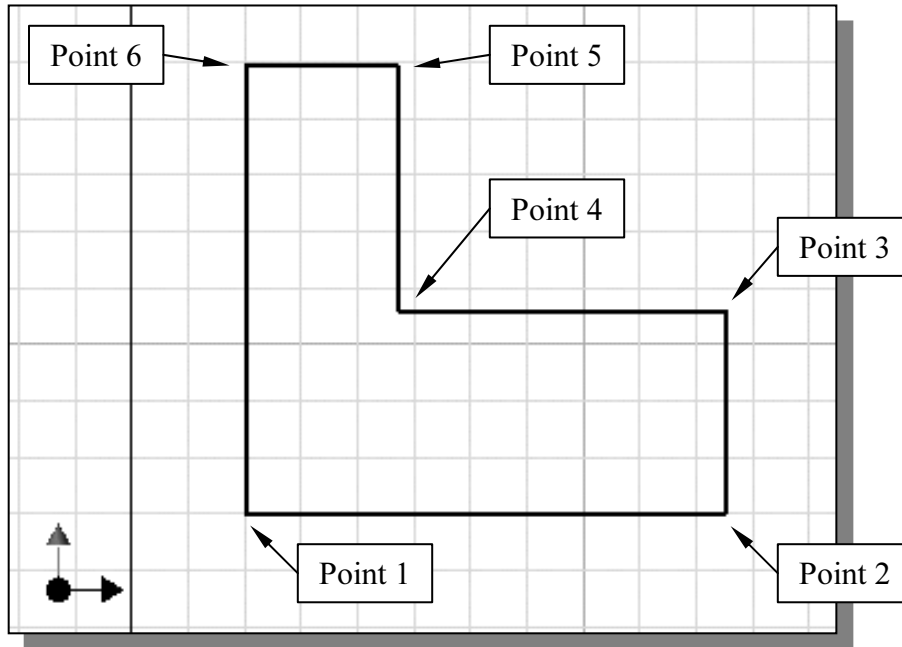

- Inside the graphics window, click once with the **right-mouse-button** to display the option menu. Select Done[Esc] in the popup menu, or hit the [Esc] key once, to end the Sketch Line command.

Step 2: Apply/Modify Constraints and Dimensions

As the sketch is made, *Autodesk Inventor* automatically applies some of the geometric constraints (such as horizontal, parallel, and perpendicular) to the sketched geometry. We can continue to modify the geometry, apply additional constraints, and/or define the size of the existing geometry. In this example, we will illustrate adding dimensions to describe the sketched entities.

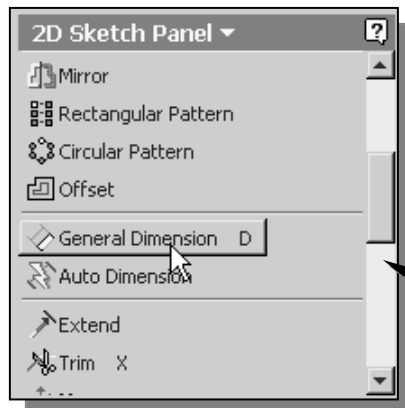

- Move the cursor to the *Sketch* toolbar area and scroll downward, by dragging the *scroll box* with the left-mouse-button, so that the **General Dimension** icon is visible as shown.

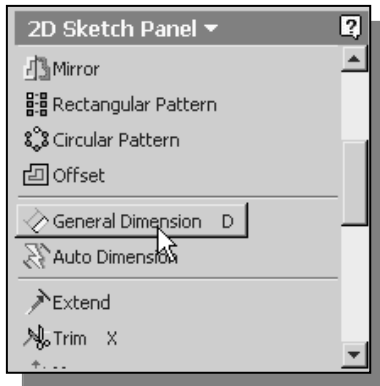

2. Move the cursor on top of the **General Dimension** icon. The **General Dimension** command allows us to quickly create and modify dimensions. Left-click once on the icon to activate the **General Dimension** command.
3. The message “*Select Geometry to Dimension*” is displayed in the *Status Bar* area at the bottom of the *Inventor* window. Select the bottom right horizontal line by left-clicking once on the line.

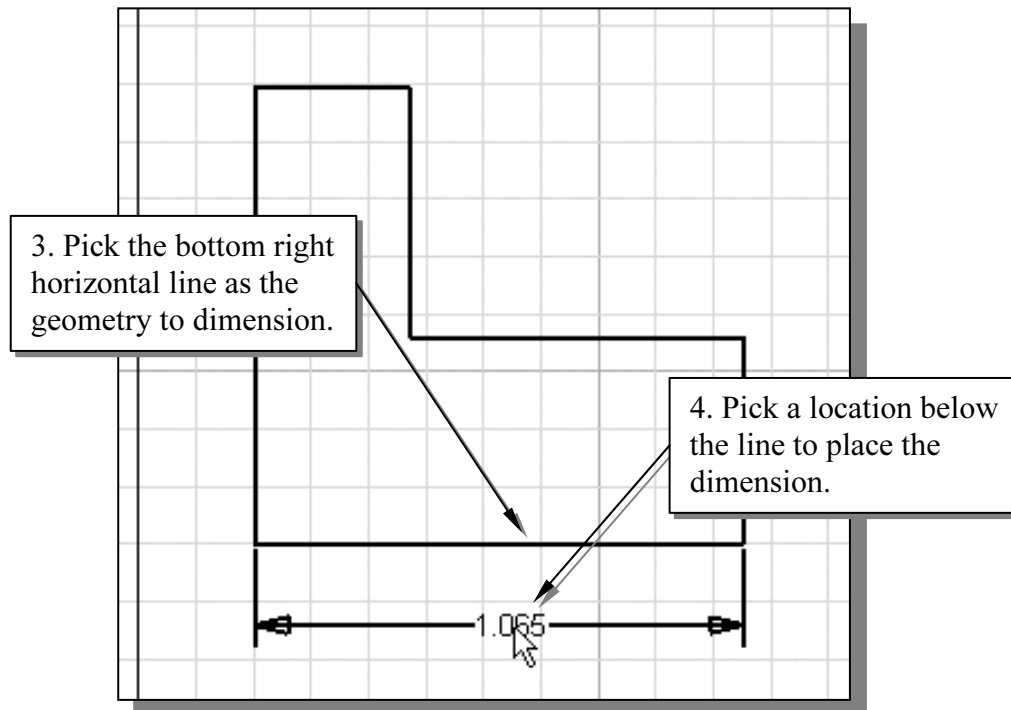

4. Move the graphics cursor below the selected line and left-click to place the dimension. (Note that the value displayed on your screen might be different than what is shown in the figure above.)
 5. The message “*Select Geometry to Dimension*” is displayed in the *Status Bar* area, at the bottom of the *Inventor* window. Select the lower right-vertical line.
 6. Pick a location toward the right of the sketch to place the dimension.
- The **General Dimension** command will create a length dimension if a single line is selected.

7. The message “*Select Geometry to Dimension*” is displayed in the *Status Bar* area, at the bottom of the *Inventor* window. Select the top-horizontal line as shown below.
8. Select the bottom-horizontal line as shown below.
9. Pick a location to the left of the sketch to place the dimension.

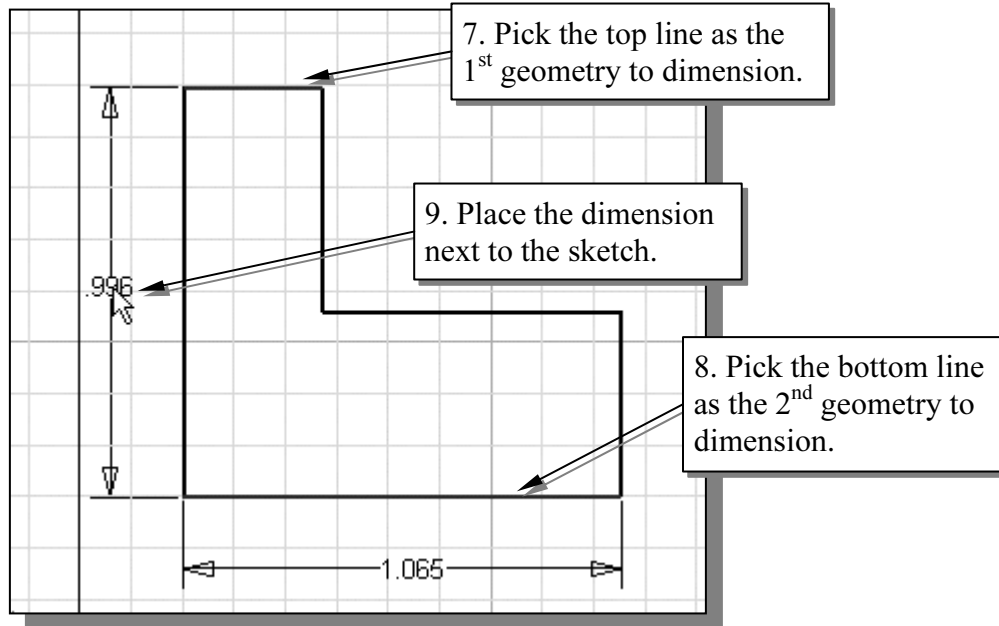

- When two parallel lines are selected, the **General Dimension** command will create a dimension measuring the distance between them.

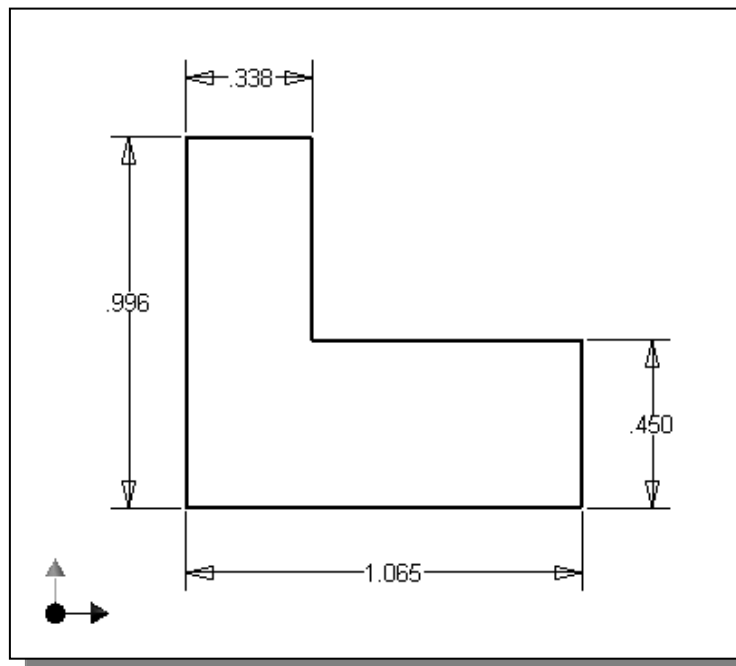

10. On your own, repeat the above steps and create additional dimensions so that the sketch appears as shown.

Modifying the Dimensions of the Sketch

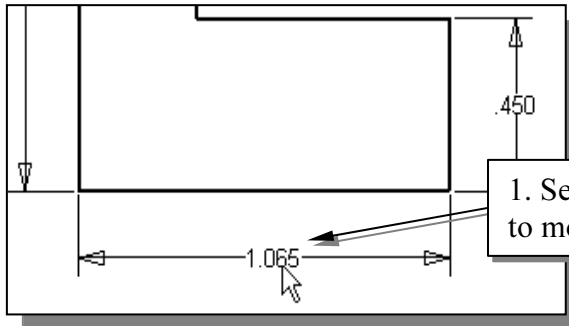

1. Select the dimension that is to the bottom of the sketch by left-clicking once on the dimension text.

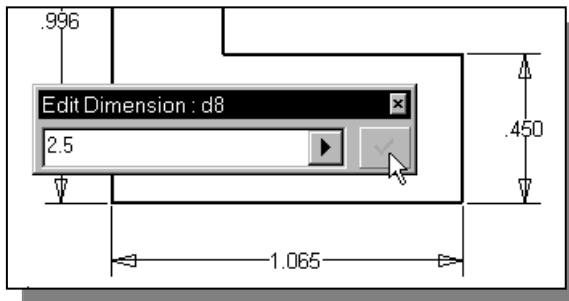

2. In the *Edit Dimension* window, the current length of the line is displayed. Enter **2.5** to set the length of the line.
3. Click on the **Accept** icon to accept the entered value.

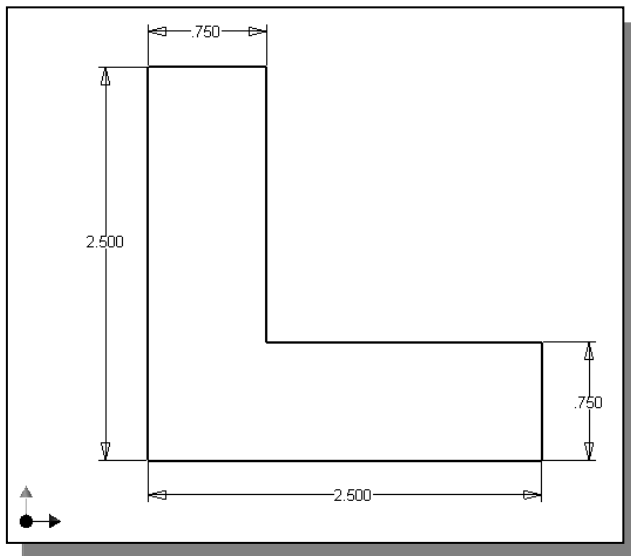

- ❖ *Autodesk Inventor* will now update the profile with the new dimension value.
4. On you own, repeat the above steps and adjust the dimensions so that the sketch appears as shown.



5. Inside the graphics window, click once with the **right-mouse-button** to display the option menu. Select **Done** in the popup menu to end the **General Dimension** command.

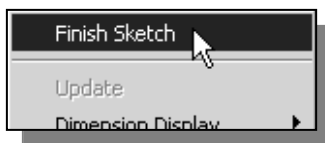

6. Inside the graphics window, click once with the **right-mouse-button** and select **Finish Sketch** in the popup menu to end the **Sketch** option.

Step 3: Completing the Base Solid Feature

Now that the 2D sketch is completed, we will proceed to the next step: create a 3D part from the 2D profile. Extruding a 2D profile is one of the common methods that can be used to create 3D parts. We can extrude planar faces along a path. We can also specify a height value and a tapered angle. In *Autodesk Inventor*, each face has a positive side and a negative side, the current face we're working on is set as the default positive side. This positive side identifies the positive extrusion direction and it is referred to as the face's *normal*.

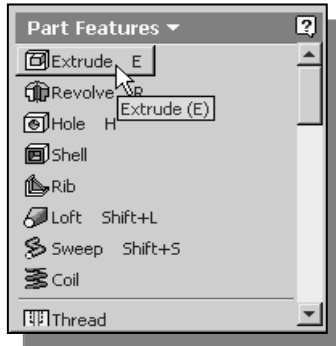

1. In the *Part Features* toolbar (the toolbar that is located to the left side of the graphics window), select the **Extrude** command by releasing the left-mouse-button on the icon.

2. In the *Extrude* popup window, enter **2.5** as the extrusion distance. Notice that the sketch region is automatically selected as the extrusion profile.

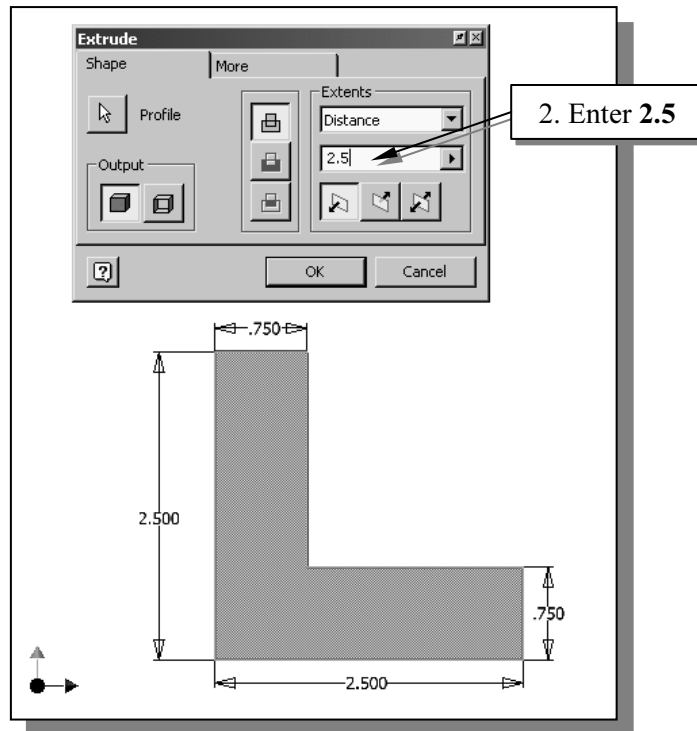

3. Click on the **OK** button to proceed with creating the 3D part.
- Note that all dimensions disappeared from the screen. All parametric definitions are stored in the *Autodesk Inventor* database and any of the parametric definitions can be displayed and edited at any time.

Isometric View

Autodesk Inventor provides many ways to display views of the three-dimensional design. Several options are available that allow us to quickly view the design to track the overall effect of any changes being made to the model. We will first orient the model to display in the *isometric view*, by using the pull-down menu.

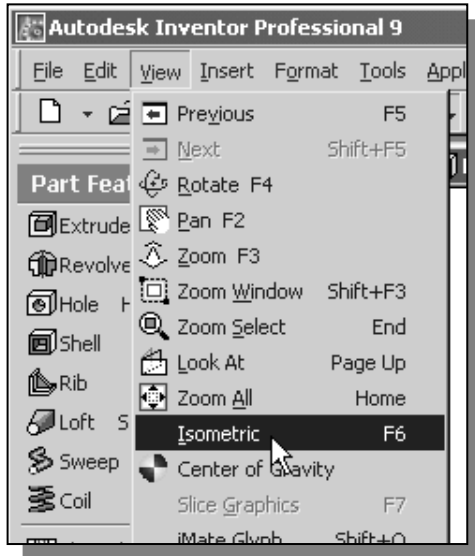

1. Select **Isometric View** in the **View** pull-down menu to change the display to the isometric view. (Note that **F6** can also be used to activate this command.)

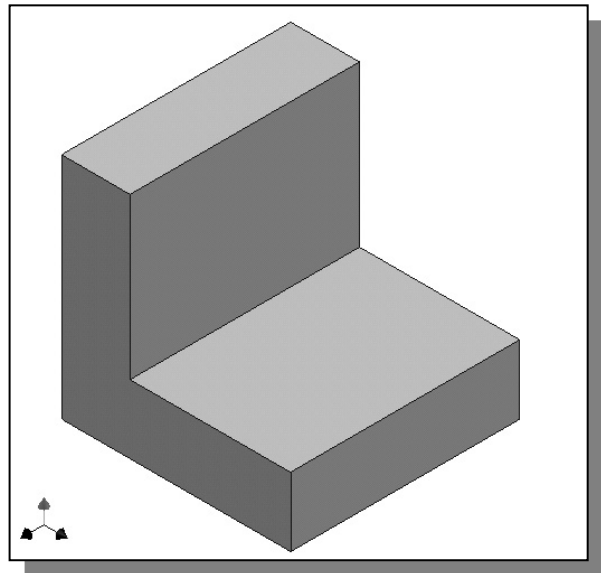

- Notice the other view-related commands that are available under the **View** pull-down menu. Most of these commands are also accessible through the *Standard* toolbar and/or *function keys*.

Dynamic Viewing Functions - Zoom and Pan

Autodesk Inventor provides a special user interface called *Dynamic Viewing* that enables convenient viewing of the entities in the graphics window.



1. Click on the **Zoom** icon, located in the *Standard* toolbar as shown.
2. Move the cursor near the center of the graphics window.
3. Inside the graphics window, **press and hold down the left-mouse-button**, then move downward to enlarge the current display scale factor.

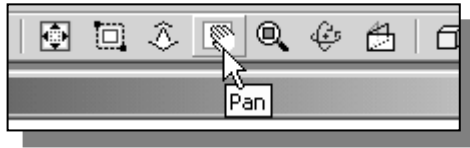

4. Press the **[Esc]** key once to exit the **Zoom** command.
 5. Click on the **Pan** icon, located next to the **Zoom** command in the *Standard* toolbar. The icon is the picture of a hand.
- The **Pan** command enables us to move the view to a different position. This function acts as if you are using a video camera.
6. On your own, use the **Zoom** and **Pan** options to reposition the sketch near the center of the screen.

Dynamic Rotation of the 3D Block - 3D Rotate

The 3D Rotate command allows us to:

- Rotate a part or assembly in the graphics window. Rotation can be around the center mark, free in all directions, or around the X/Y-axes in the *3D-Rotate* display.
- Reposition the part or assembly in the graphics window.
- Display isometric or standard orthographic views of a part or assembly.
- The 3D Rotate tool is accessible while other tools are active. *Autodesk Inventor* remembers the last used mode when you exit the **Rotate** command.



1. Click on the **Rotate** icon in the *Standard* toolbar.

The *3D Rotate* display is a circular rim with four handles and a center mark. *3D Rotate* enables us to manipulate the view of 3D objects by clicking and dragging with the left-mouse-button:

- Drag with the left-mouse-button near the center for free rotation.
- Drag on the handles to rotate around the horizontal or vertical axes.
- Drag on the rim to rotate about an axis that is perpendicular to the displayed view.
- Single left-mouse-click to align the center mark of the view.

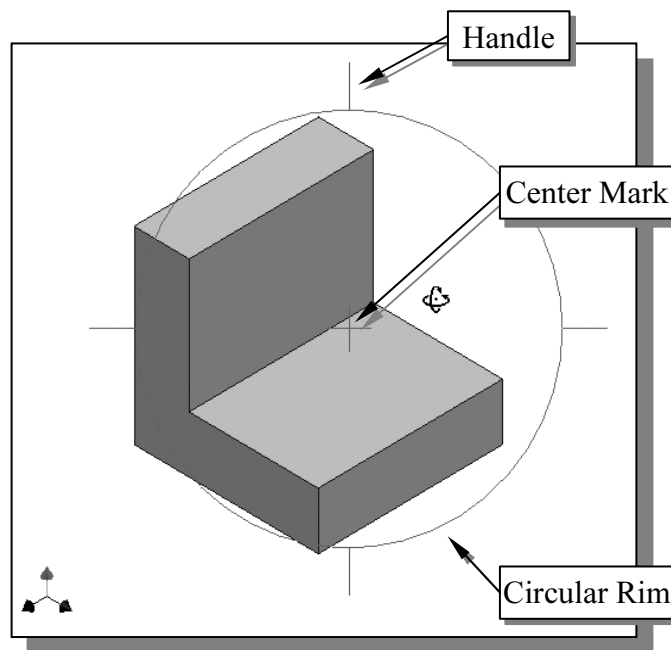

2. Inside the *circular rim*, press down the left-mouse-button and drag in an arbitrary direction; the **3D Rotate** command allows us to freely rotate the solid model.
3. Move the cursor near the circular rim and notice the cursor symbol changes to a single circle. Drag with the left-mouse-button to rotate about an axis that is perpendicular to the displayed view.
4. Single left-mouse-click near the top-handle to align the selected location to the center mark in the graphics window.
5. Press the [**Space bar**] to activate the **Common Views** option.

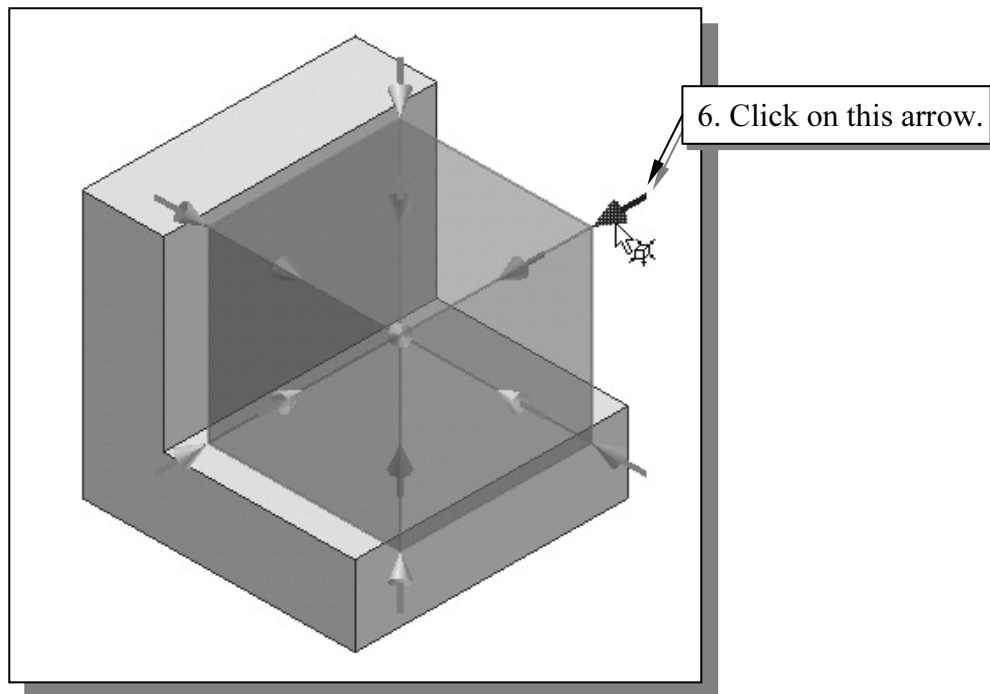

6. The displayed arrows represent the viewing directions of the pre-defined common views. Change the viewing direction by left-clicking once on the top-right arrow as shown in the figure above. Hit the [**Esc**] key once to exit the **3D Rotate** command.
7. On your own, use the different options described in the above steps and familiarize yourself with the **3D Rotate** command. Reset the display to the *Isometric* view as shown in the above figure before continuing to the next section.

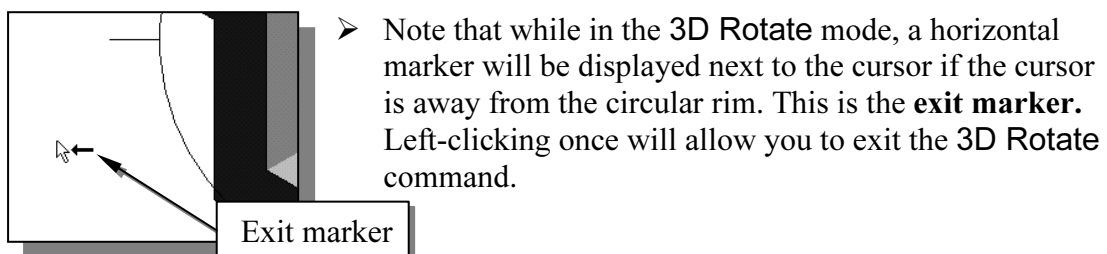

- Note that while in the **3D Rotate** mode, a horizontal marker will be displayed next to the cursor if the cursor is away from the circular rim. This is the **exit marker**. Left-clicking once will allow you to exit the **3D Rotate** command.

Dynamic Viewing - Quick Keys

We can also use the function keys on the keyboard and the mouse to access the *Dynamic Viewing* functions.

❖ Panning – F2 and the mouse

Hold the **F2** function key down, and drag with the left-mouse-button to pan the display. This allows you to reposition the display while maintaining the same scale factor of the display.

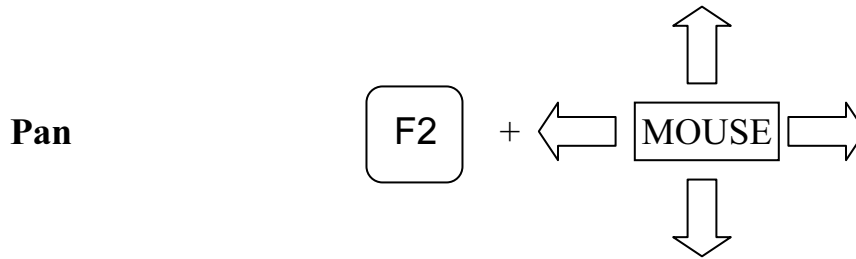

❖ Zooming – F3 and the mouse

Hold the **F3** function key down, and drag with the left-mouse-button vertically on the screen to adjust the scale of the display. Moving upward will reduce the scale of the display, making the entities display smaller on the screen. Moving downward will magnify the scale of the display.

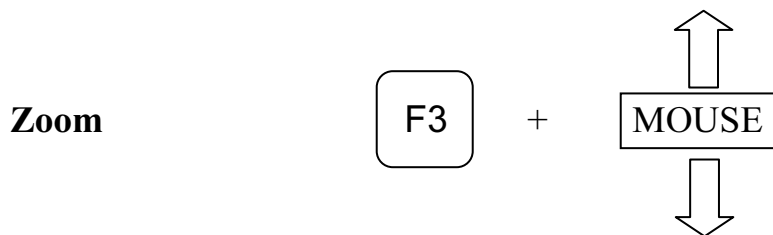

❖ 3D Dynamic Rotation – F4 and the mouse

Hold the **F4** function key down and move the mouse to rotate the display. The 3D Rotate rim with four handles and the center mark appears on the screen. Note that the **Common View** option is not available when using the **F4** quick key.

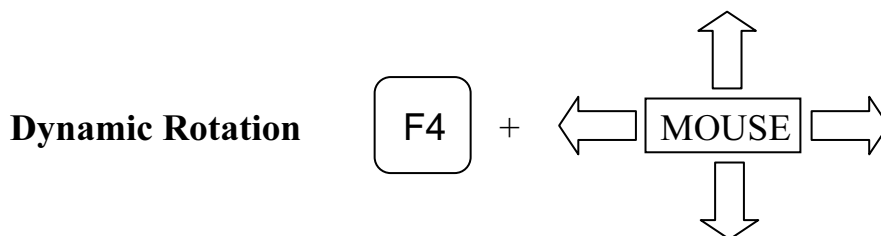

Display Modes

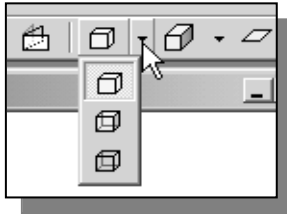

The display in the graphics window has three basic display-modes: wireframe, shaded, and shaded with hidden edge display. To change the display mode in the active window, click on the triangle icon next to the display mode button on the *Standard* toolbar, as shown in the figure.



❖ **Shaded Solid:**

The first icon in the display mode button group generates a shaded image of the 3D object.



❖ **Hidden-Edge Display:**

The second icon in the display mode button group can be used to generate an image of the 3D object with all the back lines shown.

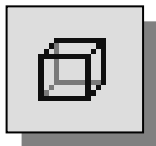

❖ **Wireframe Image:**

The third icon in the display mode button group allows the display of the 3D objects using the basic wireframe representation scheme.

Orthographic vs. Perspective

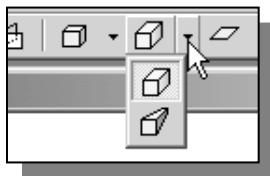

Besides the three basic display modes, we can also choose orthographic view or perspective view of the display. Click on the icon next to the display mode button on the *Standard* toolbar, as shown in the figure.



❖ **Orthographic Camera**

The first icon allows the display of the 3D object using the orthographics, parallel edges, representation scheme.



❖ **Perspective Camera**

The second icon allows the display of the 3D object using the perspective, nonparallel edges representation scheme.

- On your own, use the different options described in the above sections to familiarize yourself with the 3D viewing/display commands. Reset the display to the standard **isometric view** before continuing to the next section.

Sketch Plane – It is an XY CRT, but an XYZ World

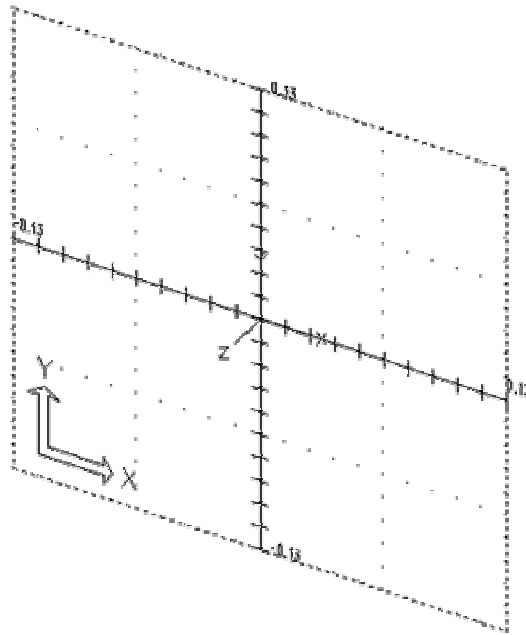

Design modeling software is becoming more powerful and user friendly, yet the system still does only what the user tells it to do. When using a geometric modeler, we therefore need to have a good understanding of what its inherent limitations are. We should also have a good understanding of what we want to do and what to expect, as the results are based on what is available.

In most 3D geometric modelers, 3D objects are located and defined in what is usually called **world space** or **global space**. Although a number of different coordinate systems can be used to create and manipulate objects in a 3D modeling system, the objects are typically defined and stored using the world space. The world space is usually a **3D Cartesian coordinate system** that the user cannot change or manipulate.

In most engineering designs, models can be very complex, and it would be tedious and confusing if only the world coordinate system were available. Practical 3D modeling systems allow the user to define **Local Coordinate Systems (LCS)** or **User Coordinate Systems (UCS)** relative to the world coordinate system. Once a local coordinate system is defined, we can then create geometry in terms of this more convenient system.

Although objects are created and stored in 3D space coordinates, most of the geometry entities can be referenced using 2D Cartesian coordinate systems. Typical input devices such as a mouse or digitizers are two-dimensional by nature; the movement of the input device is interpreted by the system in a planar sense. The same limitation is true of common output devices, such as CRT displays and plotters. The modeling software performs a series of three-dimensional to two-dimensional transformations to correctly project 3D objects onto a 2D picture plane.

The *Autodesk Inventor sketch plane* is a special construction tool that enables the planar nature of 2D input devices to be directly mapped into the 3D coordinate system. The *sketch plane* is a local coordinate system that can be aligned to the world coordinate system, an existing face of a part, or a reference plane. By default, the *sketch plane* is aligned to the world coordinate system.

Think of a sketch plane as the surface on which we can sketch the 2D profiles of the parts. It is similar to a piece of paper, a white board, or a chalkboard that can be attached to any planar surface. The first profile we create is usually drawn on the default sketch plane, which is in the current coordinate system. Subsequent profiles can then be drawn on sketch planes that are defined on **planar faces of a part, work planes attached to part geometry, or sketch planes attached to a coordinate system** (such as the World XY, XZ, and YZ sketch planes). The model we have created so far used the default settings where the sketch plane is aligned to the XY plane of the world coordinate system.

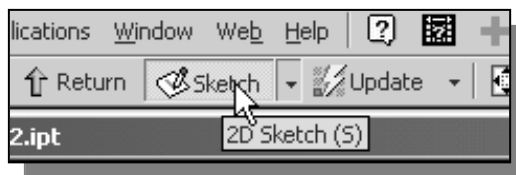

1. In the *Standard* toolbar select the **Sketch** command by left-clicking once on the icon.

2. In the *Status Bar* area, the message: “*Select face, workplane, sketch or sketch geometry*” is displayed. *Autodesk Inventor* expects us to identify a planar surface where the 2D sketch of the next feature is to be created. Move the graphics cursor on the 3D part and notice that *Autodesk Inventor* will automatically highlight feasible planes and surfaces as the cursor is on top of the different surfaces. Pick the top horizontal face of the 3D solid object.

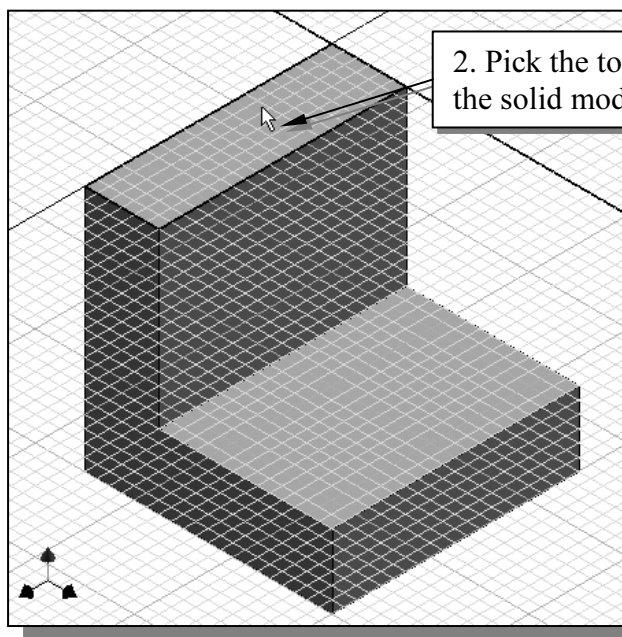

- Note that the sketch plane is aligned to the selected face. *Autodesk Inventor* automatically establishes a User-Coordinate-System (UCS), and records its location with respect to the part on which it was created.

Step 4-1: Adding an extruded feature

Next, we will create and profile another sketch, a rectangle, which will be used to create another extrusion feature that will be added to the existing solid object.

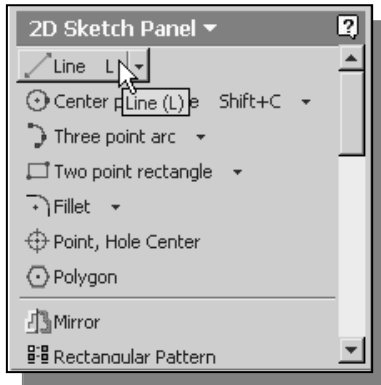

1. Select the **Line** command by clicking once with the **left-mouse-button** on the icon in the *Sketch* toolbar.

2. Create a sketch with segments perpendicular/parallel to the existing edges of the solid model as shown below.

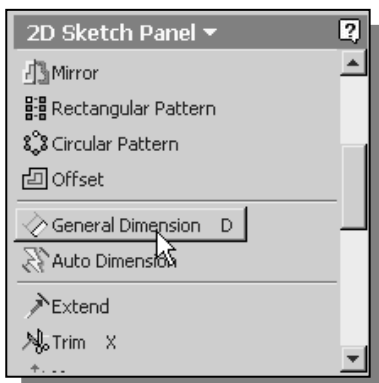
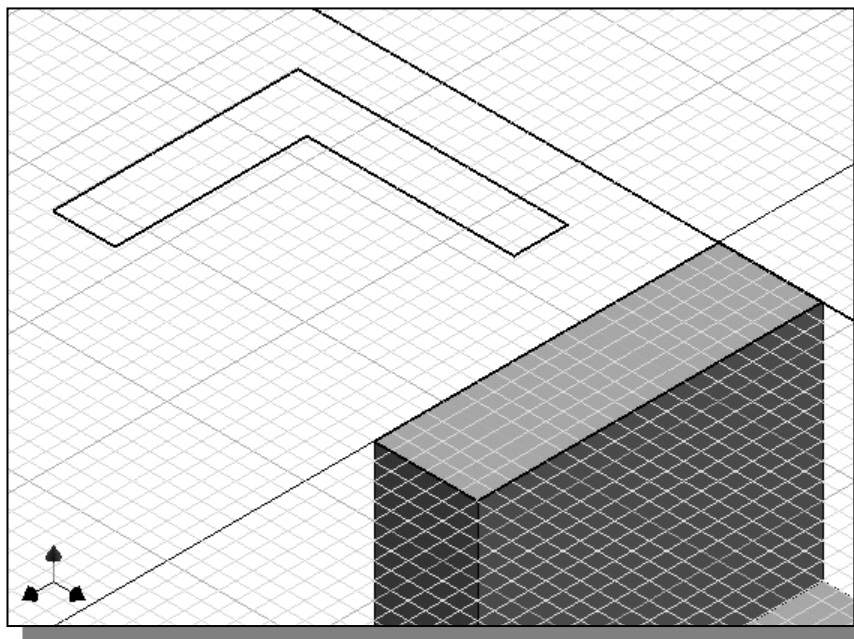

3. Select the **General Dimension** command in the *Sketch* toolbar. The **General Dimension** command allows us to quickly create and modify dimensions. Left-click once on the icon to activate the **General Dimension** command.

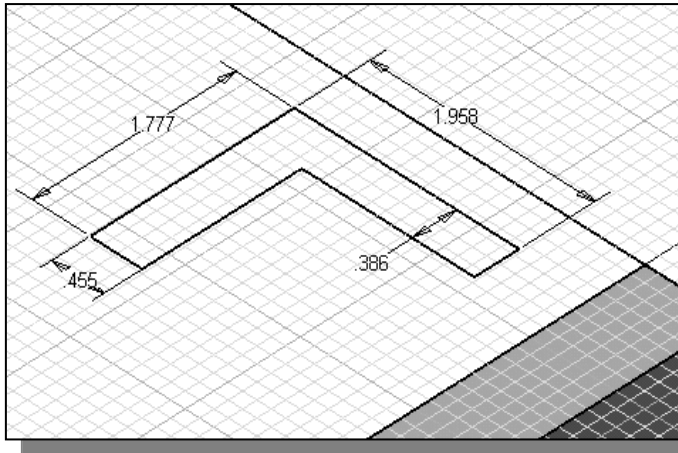

4. The message “*Select Geometry to Dimension*” is displayed in the *Status Bar* area, at the bottom of the *Inventor* window. Create the four dimensions to describe the size of the sketch as shown in the figure.

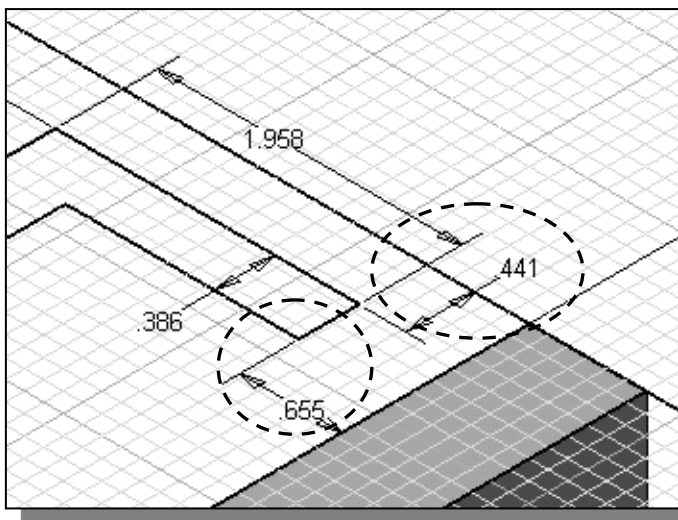

5. Create the two location dimensions to describe the position of the sketch relative to the top corner of the solid model as shown.

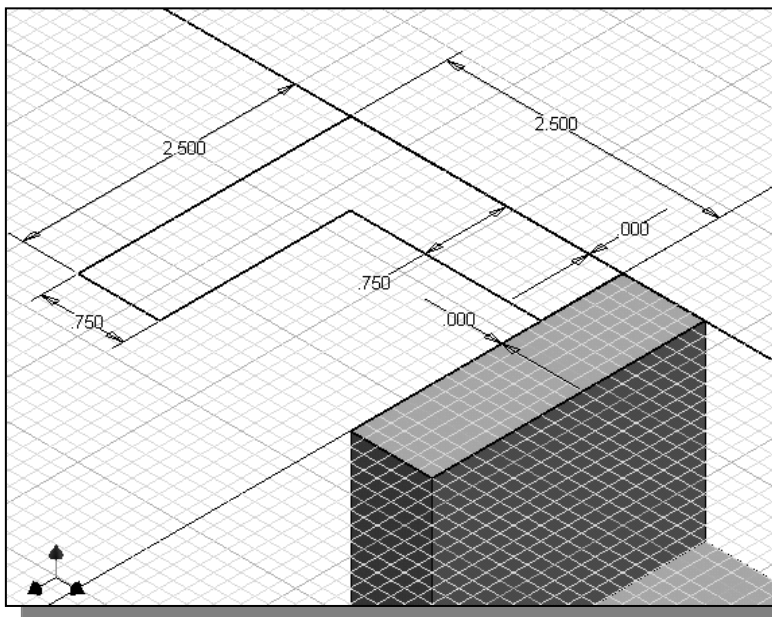

6. On your own, modify the two location dimensions to **0.0** and the size dimensions as shown in the below figure.



7. Inside the graphics window, click once with the **right-mouse-button** to display the option menu. Select **Done** in the popup menu to end the **General Dimension** command.



8. Inside the graphics window, click once with the **right-mouse-button** to display the option menu. Select **Finish Sketch** in the popup menu to end the **Sketch** option.

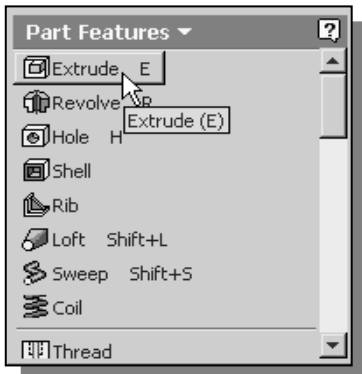

9. In the *Part Features* toolbar (the toolbar that is located to the left side of the graphics window), select the **Extrude** command by releasing the left-mouse-button on the icon.

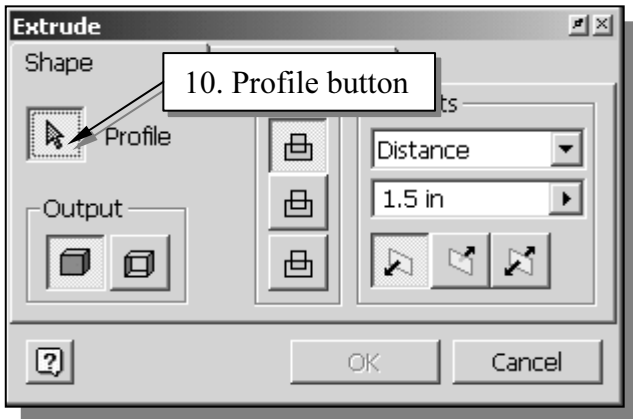

10. In the *Extrude* popup window, the **Profile** button is pressed down; *Autodesk Inventor* expects us to identify the profile to be extruded.

11. Move the cursor inside the rectangle we just created and left-click once to select the region as the profile to be extruded.

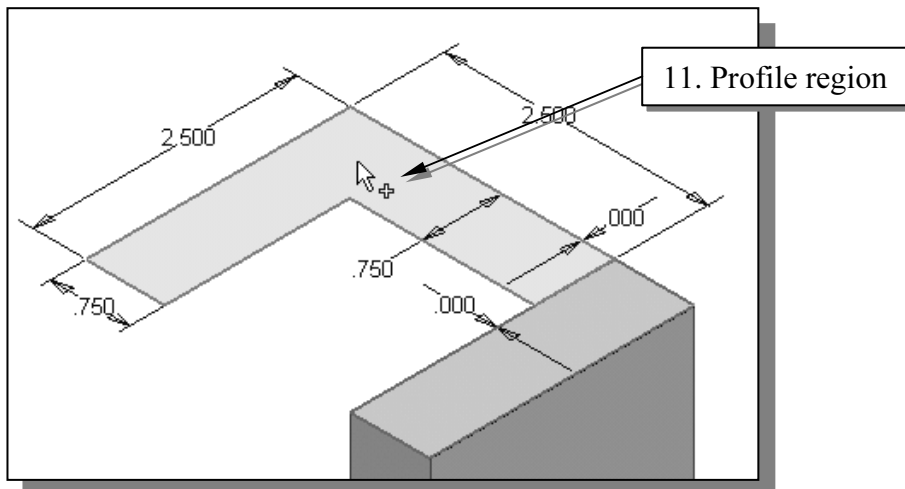

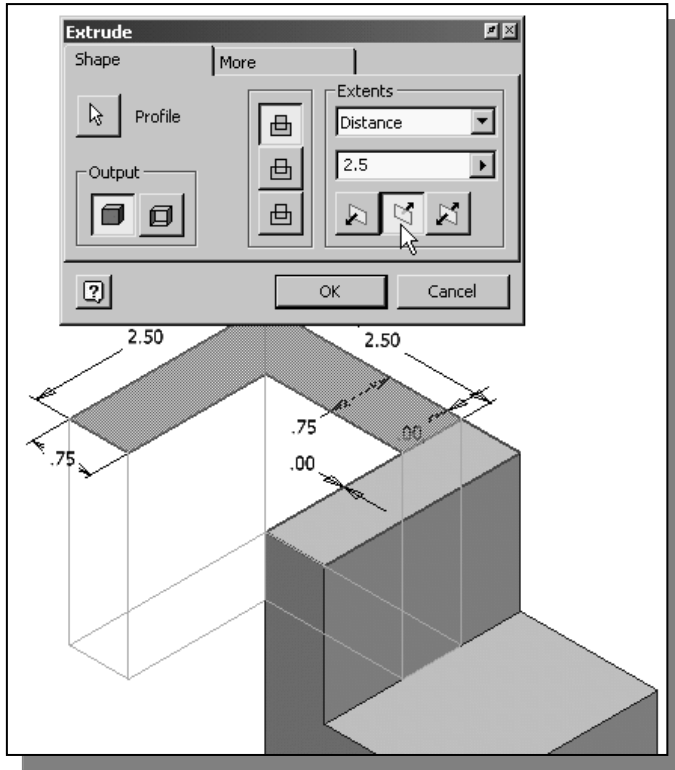

12. In the *Extrude* popup window, enter **2.5** as the extrude distance as shown.

13. Click on the second **direction icon** to set the extrusion direction downward as shown.

14. Click on the **OK** button to proceed with creating the extruded feature.

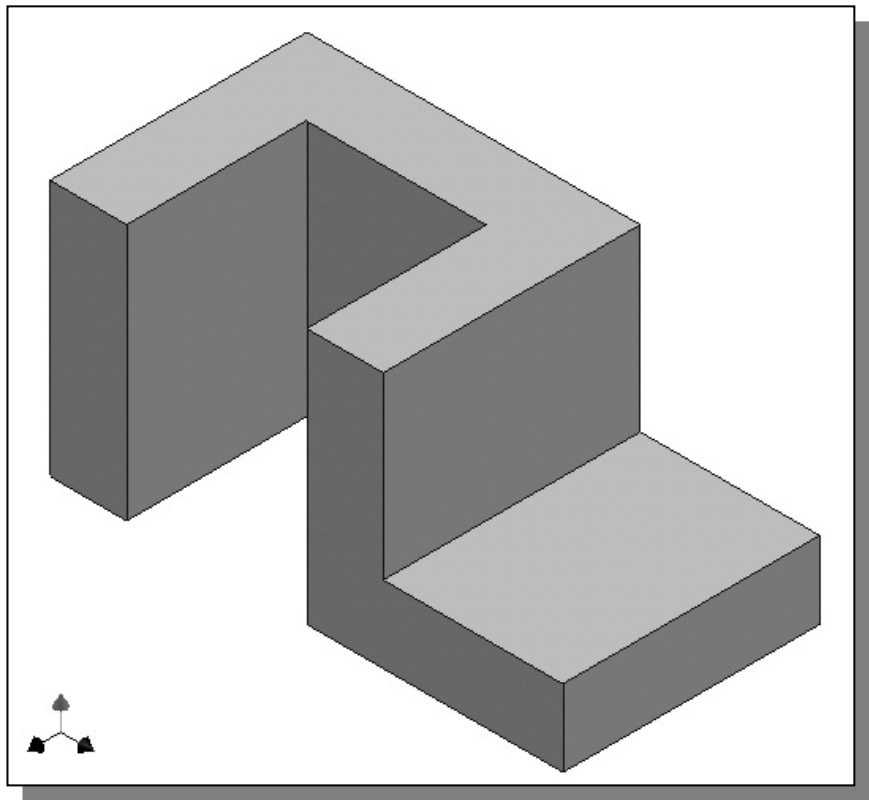
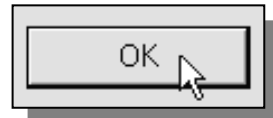

Step 4-2: Adding a Cut Feature

Next, we will create and profile a circle, which will be used to create a **cut** feature that will be added to the existing solid object.

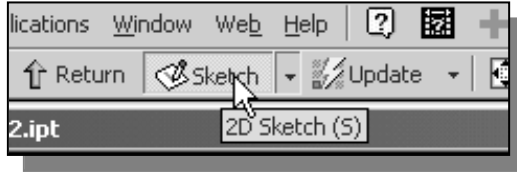

1. In the *Standard* toolbar select the **Sketch** command by left-clicking once on the icon.

2. In the *Status Bar* area, the message: “*Select face, workplane, sketch or sketch geometry.*” is displayed. *Autodesk Inventor* expects us to identify a planar surface where the 2D sketch of the next feature is to be created. Pick the top horizontal face of the 3D solid model as shown.

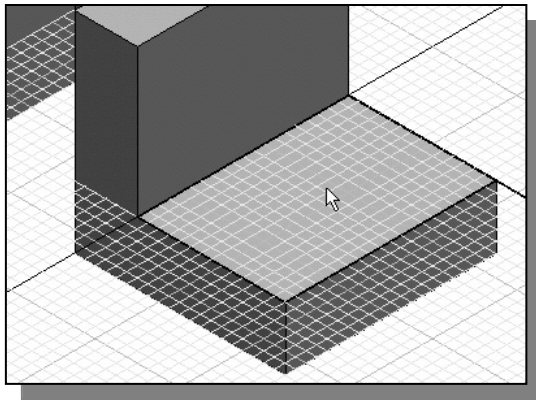

- Note that the sketch plane is aligned to the selected face. *Autodesk Inventor* automatically establishes a User-Coordinate-System (UCS), and records its location with respect to the part on which it was created.

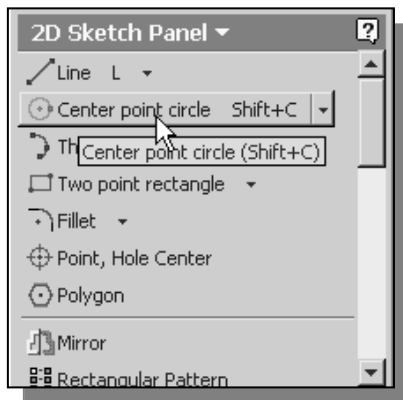

3. Select the **Center point circle** command by clicking once with the **left-mouse-button** on the icon in the *Sketch* toolbar.

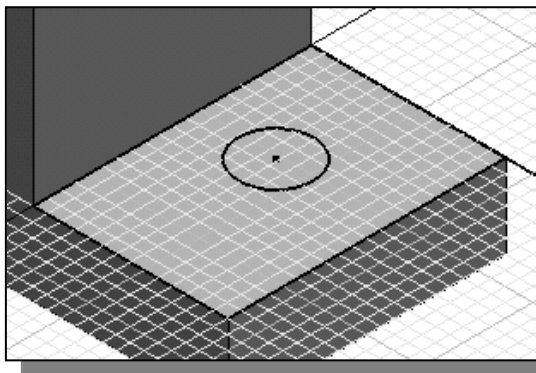

4. Create a circle of arbitrary size on the top face of the solid model as shown.

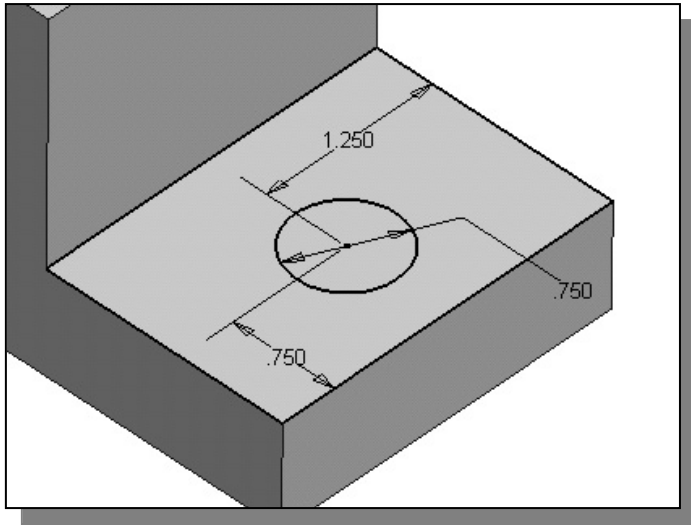

5. On your own, create and modify the dimensions of the sketch as shown in the figure.

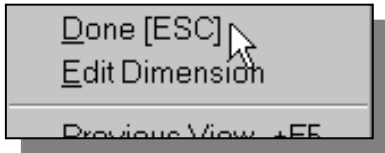

6. Inside the graphics window, click once with the **right-mouse-button** to display the option menu. Select **Done** in the popup menu to end the **General Dimension** command.



7. Inside the graphics window, click once with the **right-mouse-button** to display the option menu. Select **Finish Sketch** in the popup menu to end the **Sketch** option.

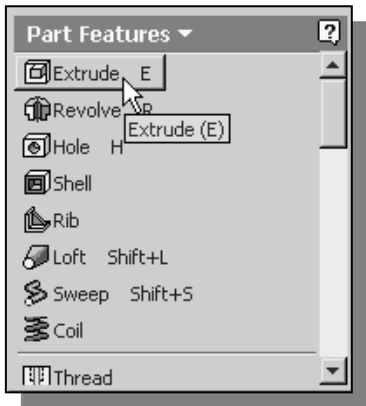

8. In the *Part Features* toolbar (the toolbar that is located to the left side of the graphics window), select the **Extrude** command by releasing the left-mouse-button on the icon.

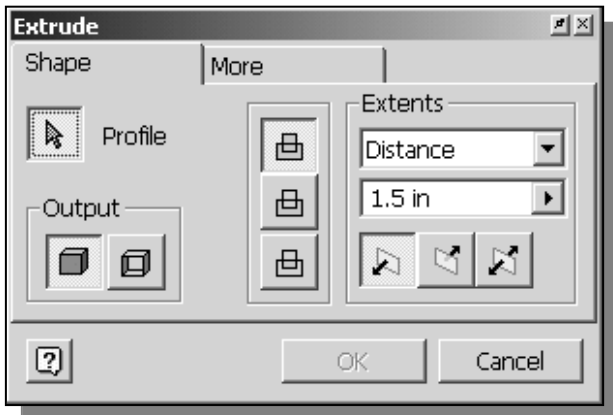

9. In the *Extrude* popup window, the **Profile** button is pressed down; *Autodesk Inventor* expects us to identify the profile to be extruded.

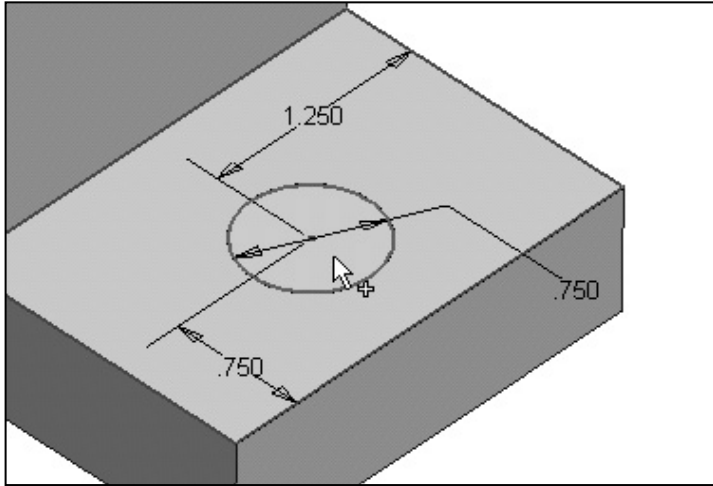

10. Click on the inside of the sketched circle as shown.

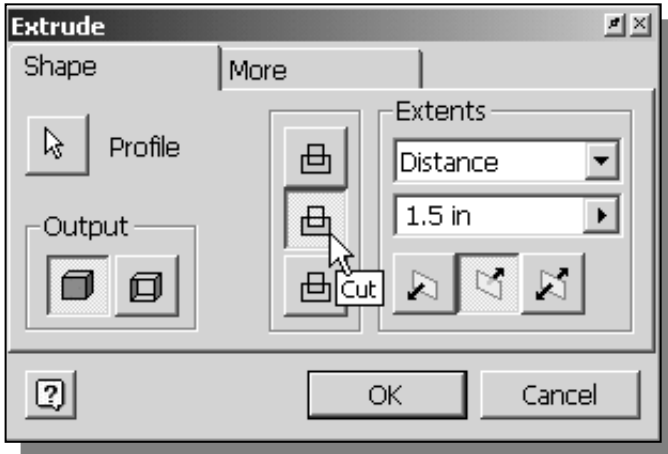

11. Click on the **CUT** icon, as shown, to set the extrusion operation to **cut**.

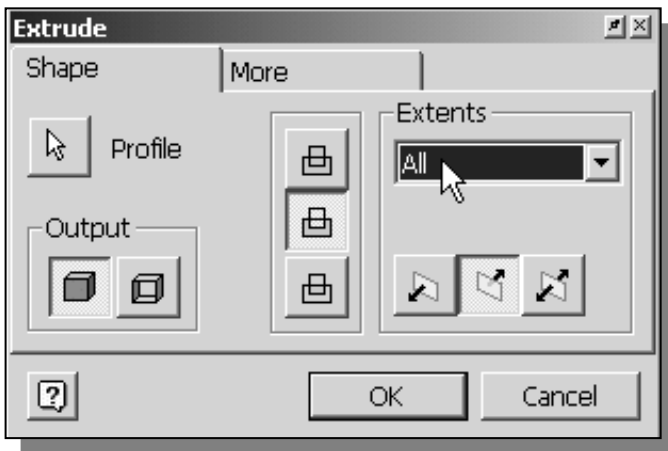

12. Set the *Extents* option to **All** as shown.



13. Click on the **OK** button to proceed with creating the extruded feature.

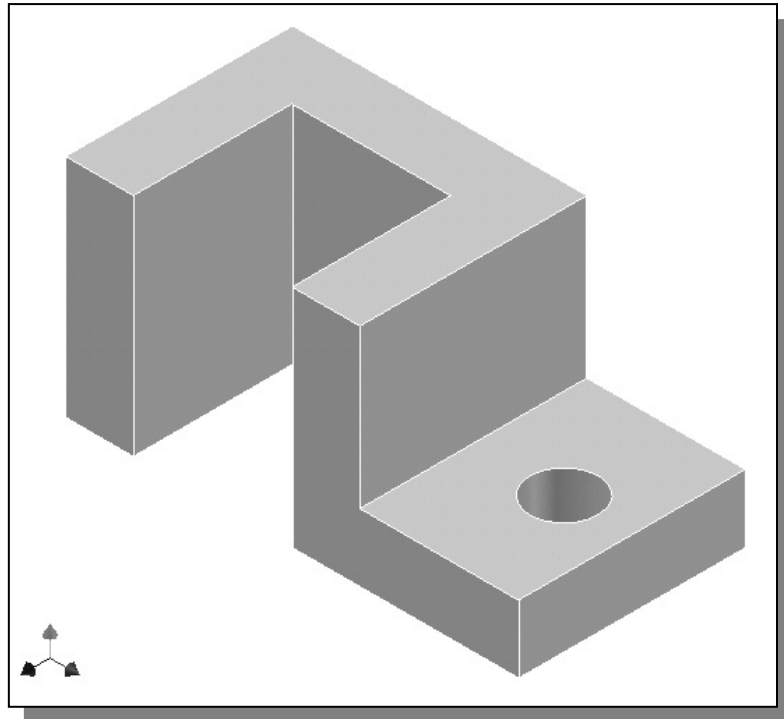

Save the Model

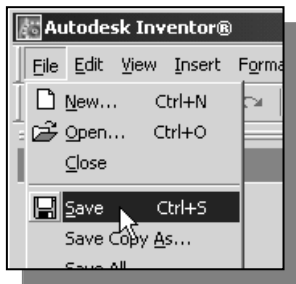

1. Select **Save** in the *Standard* toolbar, or you can also use the “**Ctrl-S**” combination (hold down the “Ctrl” key and hit the “S” key once) to save the part.
2. In the popup window, select the directory to store the model in and enter **Adjuster** as the name of the file.

3. Click on the **Save** button to save the file.

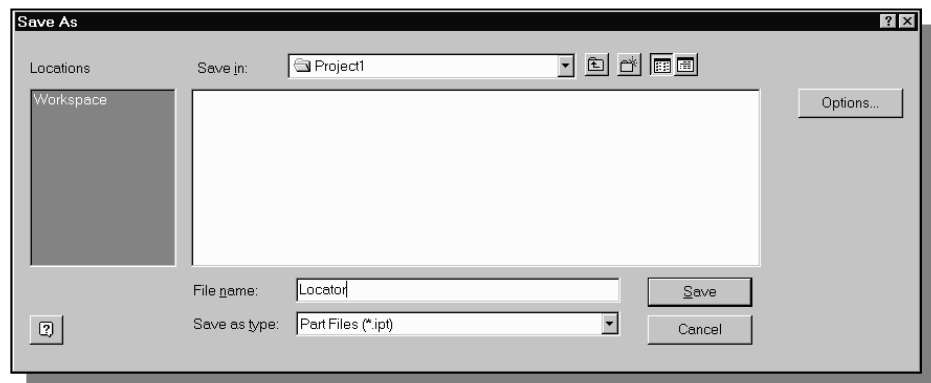

- You should form a habit of saving your work periodically, just in case something might go wrong while you are working on it. In general, one should save one’s work at an interval of every 15 to 20 minutes. One should also save before making any major modifications to the model.

Questions:

1. What is the first thing we should set up in *Autodesk Inventor* when creating a new model?
2. Describe the general *parametric modeling* procedure.
3. What is the main difference between a rough sketch and a *profile*?
4. List two of the geometric constraint symbols used by *Autodesk Inventor*.
5. What was the first feature we created in this lesson?
6. Describe the steps required to define the orientation of the sketching plane?
7. Identify the following commands:

(a)

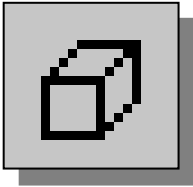

(b)



(c)

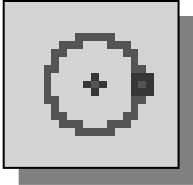

(d)

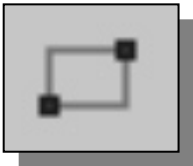

Exercises: (All dimensions are in inches.)

1. Plate Thickness: **.25**

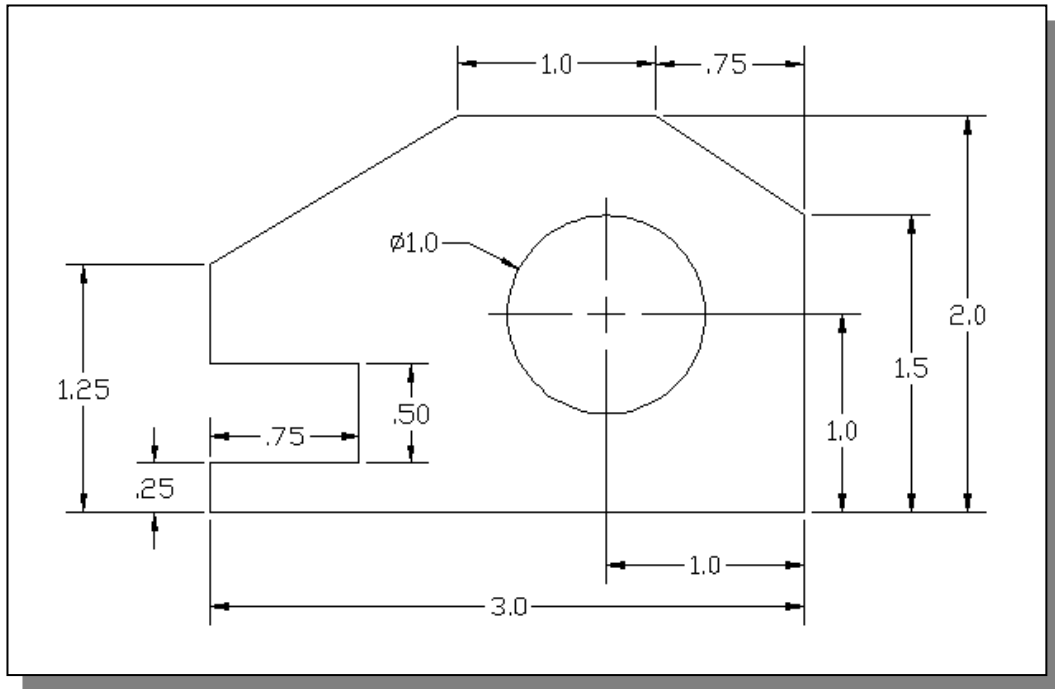

2. Plate Thickness: **.5**

